



THIS DRAWING SHALL NOT BE REPRODUCED OR IN ANY WAY UTILIZED WITHOUT WRITTEN CONSENT. ANY INFRINGEMENT WILL BE LEGALLY PURSUED.

WIRING DIAGRAM PLANT GESTION ROTARY CAPS

PROGETTAZIONE	TENSIONE ESERCIZIO	400 Vdc 3P + N + GND	FREQUENZA ESERCIZIO	50 Hz	SOFTWARE	BO_	
SERIE	TENSIONE COMANDI	24 Vdc	POTENZA ASSORBITA	5 Kw	NORMA	CEI EN 60204-1	
COMMESSA	37016	TENSIONE SEGNALI	24 Vdc	CORRENTE ASSORBITA	10 A	PROTEZIONI	
COMMITTENTE	BONINO S.p.A. Via Aldo Moro 97 15100 Alessandria Italy	CLIENTE	P & G	+ =			
			Elektroimpianti Strada Alessandria 24 15044 Quargnento (AL) www.elektroimpianti.it		 <small>di MONTAFIA ALBERTO & C. Strada Alessandria, 24 - 15044 QUARGNENTO (AL) Website : www.elektroimpianti.it - E-MAIL : info@elektroimpianti.it</small>		
			DATA	FIRME	SCHEMA ELETTRICO GESTIONE IMPIANTO ROTARY CAPS		
			DIS.	11/01/2012			FD
			VISTO				
			APPR.				
			DISEGNATO CON 		EKI_01388		
1	CABAL VIBRATOR	02/07/13	FD				
REV.	MODIFICA	DATA	FIRME	SOST. DA	SOST. IL	FILE : EKI_01388	

DISEGNATORE DESIGNER	FD	IMPIANTO PLANT	SCHEMA ELETTRICO GESTIONE IMPIANTO ROTARY CAPS WIRING DIAGRAM PLANT GESTION ROTARY CAPS				CAD	SPAC	
NOME FILE FILE NAME	EKI_01388	DATA REVISIONE REVISION DATE	REV. n° REV. nr°	COMMESSA ORDER	DATA DATE	DESCRIZIONE PAGINA PAGE DESCRIPTION	PAG.	DI OF	
SCHEMA N° DIAGRAM NR.	EKI_01388	02/07/13	1	37016	11/01/2012	DATI TECNICI TECHNICAL INFORMATION	1	38	

LISTA FOGLI \ INDEX

Foglio Sheet	Descrizione Description	Revisione \ Revision									Foglio Sheet	Descrizione Description	Revisione \ Revision								
		0	1	2	3	4	5	6	7	8			9	0	1	2	3	4	5	6	7
1	DATI TECNICI / TECHNICAL INFORMATION	/									22	INGRESSI / INPUT	/								
2	LISTA FOGLI / SHEET LIST	/									22A	INGRESSI / INPUT	/								
3	ALIMENTAZIONE / POWER SUPPLY	/									22B	USCITE / OUTPUT	/								
4	MOTORI / MOTORS	/									22C	USCITE / OUTPUT	/								
5	MOTORI / MOTORS	/									22D		/								
6	MOTORI / MOTORS	/									23	INTERFACCIA / INTERFACE	/								
7	MOTORI / MOTORS	/									24	MORSETTIERE / TERMINALS	/								
8	MOTORI / MOTORS	/									25	MORSETTIERE / TERMINALS	/								
8A	PARAMETRI INVERTER / INVERTER PARAMETER	/									26	LISTA CAVI / CABLE LIST	/								
9	AUSILIARI / AUXILIARY	/									26A	LISTA CAVI / CABLE LIST	/								
10	AUSILIARI / AUXILIARY	/									27	LAY-OUT / LAY-OUT	/								
10A	AUSILIARI / AUXILIARY	/									28	LAY-OUT / LAY-OUT	/								
11	VISIONE / VISION	/									29	LAY-OUT / LAY-OUT	/								
11A	VISIONE / VISION	/									30	LAY-OUT / LAY-OUT	/								
12	PLC / PLC	/									31	LAY-OUT / LAY-OUT	/								
13	PLC / PLC	/									31A	LAY-OUT / LAY-OUT	/								
13A	PLC / PLC	/									32	DISTINTA MATERIALI / MATERIAL LIST	/								
14	PLC / PLC	/									33	DISTINTA MATERIALI / MATERIAL LIST	/								
15	INGRESSI / INPUT	/									34	DISTINTA MATERIALI / MATERIAL LIST	/								
16	INGRESSI / INPUT	/									35	DISTINTA MATERIALI / MATERIAL LIST	/								
17	INGRESSI / INPUT	/									36	DISTINTA MATERIALI / MATERIAL LIST	/								
18	INGRESSI / INPUT	/									37	DISTINTA MATERIALI / MATERIAL LIST	/								
19		/									38		/								
20	USCITE / OUTPUT	/											/								
21	USCITE / OUTPUT	/											/								
21A		/											/								

Note :

DISEGNATORE DESIGNER	FD	IMPIANTO PLANT	SCHEMA ELETTRICO GESTIONE IMPIANTO ROTARY CAPS WIRING DIAGRAM PLANT GESTION ROTARY CAPS				CAD	SPAC	
NOME FILE FILE NAME	EKI_01388	DATA REVISIONE REVISION DATE	REV. n° REV. nr°	COMMESSA ORDER	DATA DATE	DESCRIZIONE PAGINA PAGE DESCRIPTION	PAG.	DI OF	
SCHEMA N° DIAGRAM NR.	EKI_01388	02/07/13	1	37016	11/01/2012	LISTA FOGLI SHEET LIST	2	38	

THIS DRAWING SHALL NOT BE REPRODUCED OR IN ANY WAY UTILIZED WITHOUT WRITTEN CONSENT. ANY INFRINGEMENT WILL BE LEGALLY PURSUED.

ALIMENTAZIONE
400 Vac - 50 Hz
POWER SUPPLY
400 Vac - 50 Hz

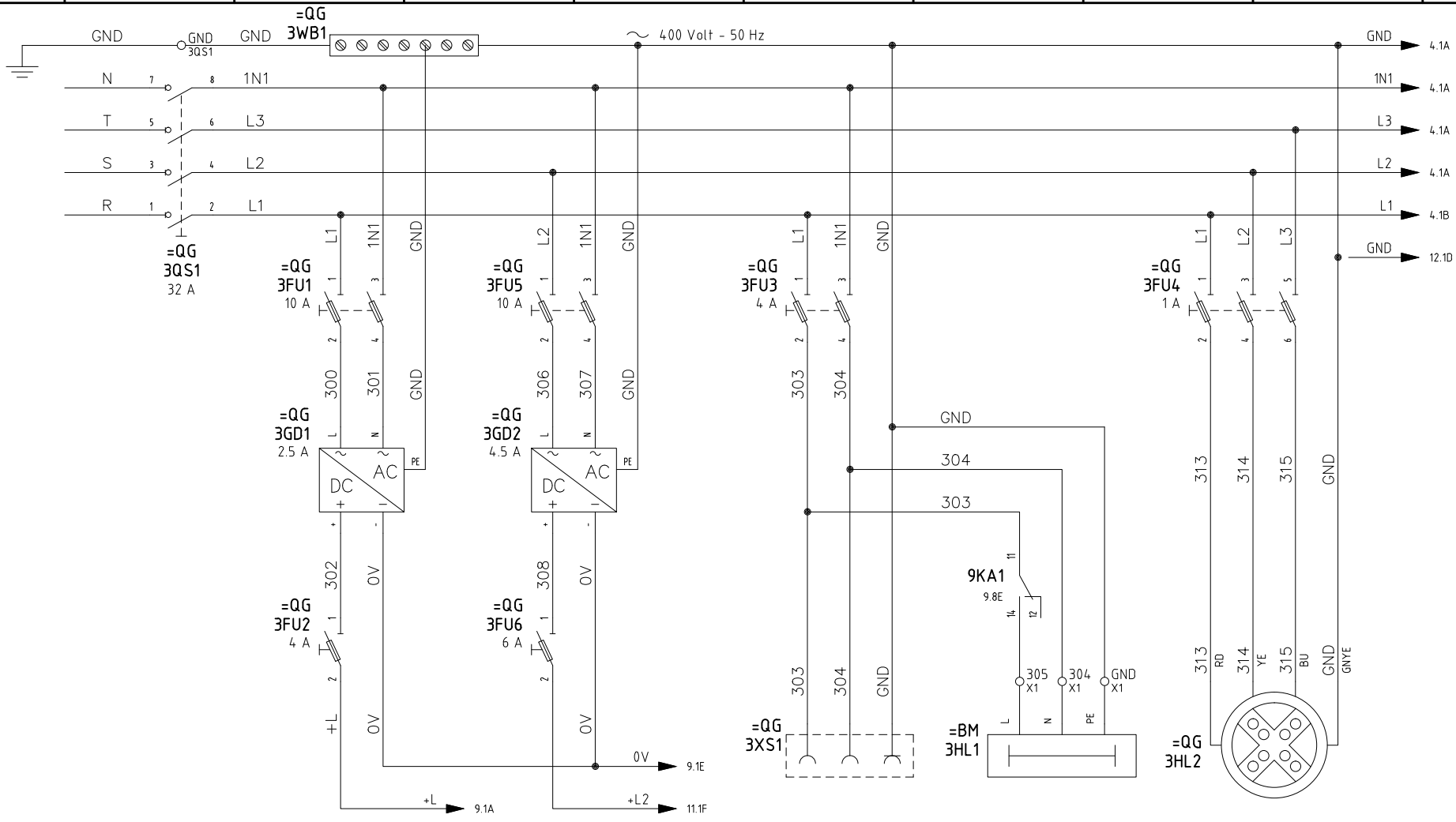

ALIMENTAZIONE
24 Vdc
POWER SUPPLY
24 Vdc

ALIMENTAZIONE
48 Vdc
POWER SUPPLY
48 Vdc

PRESA
SOCKET

ILLUMINAZIONE
BANCO
DESK
LIGHT

INDICAZIONE
TENSIONE
VOLTAGE
INDICATION

DISEGNATORE DESIGNER		FD		IMPIANTO PLANT		SCHEMA ELETTRICO GESTIONE IMPIANTO ROTARY CAPS WIRING DIAGRAM PLANT GESTION ROTARY CAPS			CAD	SPAC	
NOME FILE FILE NAME		EKI_01388		DATA REVISIONE REVISION DATE	REV. n° REV. nr°	COMMESSA ORDER	DATA DATE	DESCRIZIONE PAGINA PAGE DESCRIPTION	PAG.	DI OF	
SCHEMA N° DIAGRAM NR.		EKI_01388		02/07/13	1	37016	11/01/2012	ALIMENTAZIONE POWER SUPPLY	3	38	

THIS DRAWING SHALL NOT BE REPRODUCED OR IN ANY WAY UTILIZED WITHOUT WRITTEN CONSENT. ANY INFRINGEMENT WILL BE LEGALLY PURSUED.

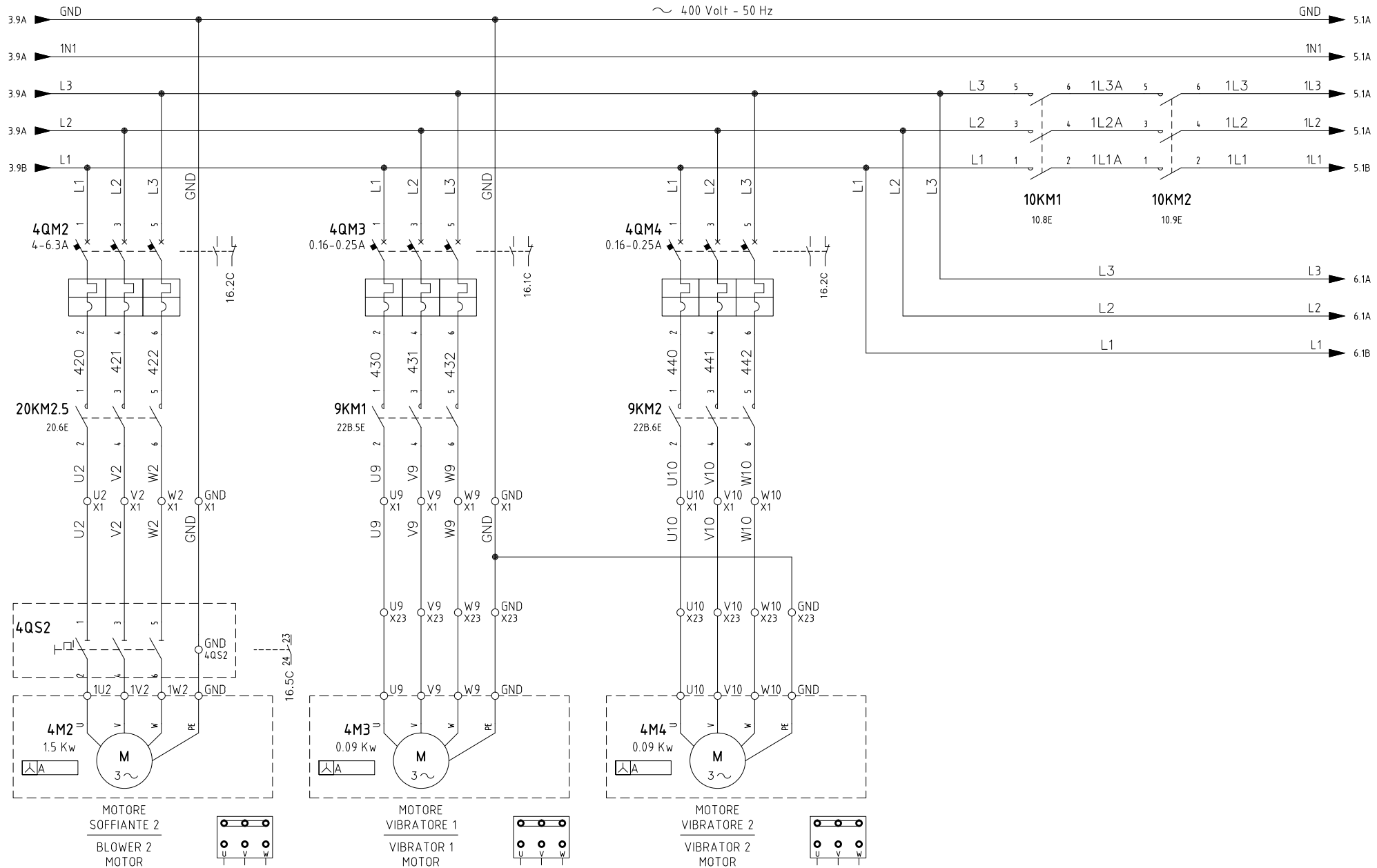

G	DISEGNATORE DESIGNER		FD		IMPIANTO PLANT		SCHEMA ELETTRICO GESTIONE IMPIANTO ROTARY CAPS WIRING DIAGRAM PLANT GESTION ROTARY CAPS			CAD		SPAC			
	NOME FILE FILE NAME		EKI_01388		DATA REVISIONE REVISION DATE		REV. n° REV. nr°		COMMESSA ORDER		DATA DATE		DESCRIZIONE PAGINA PAGE DESCRIPTION		
	SCHEMA N° DIAGRAM NR.		EKI_01388		02/07/13		1		37016		11/01/2012		MOTORI MOTORS		
												PAG.		DI OF	
												4		38	



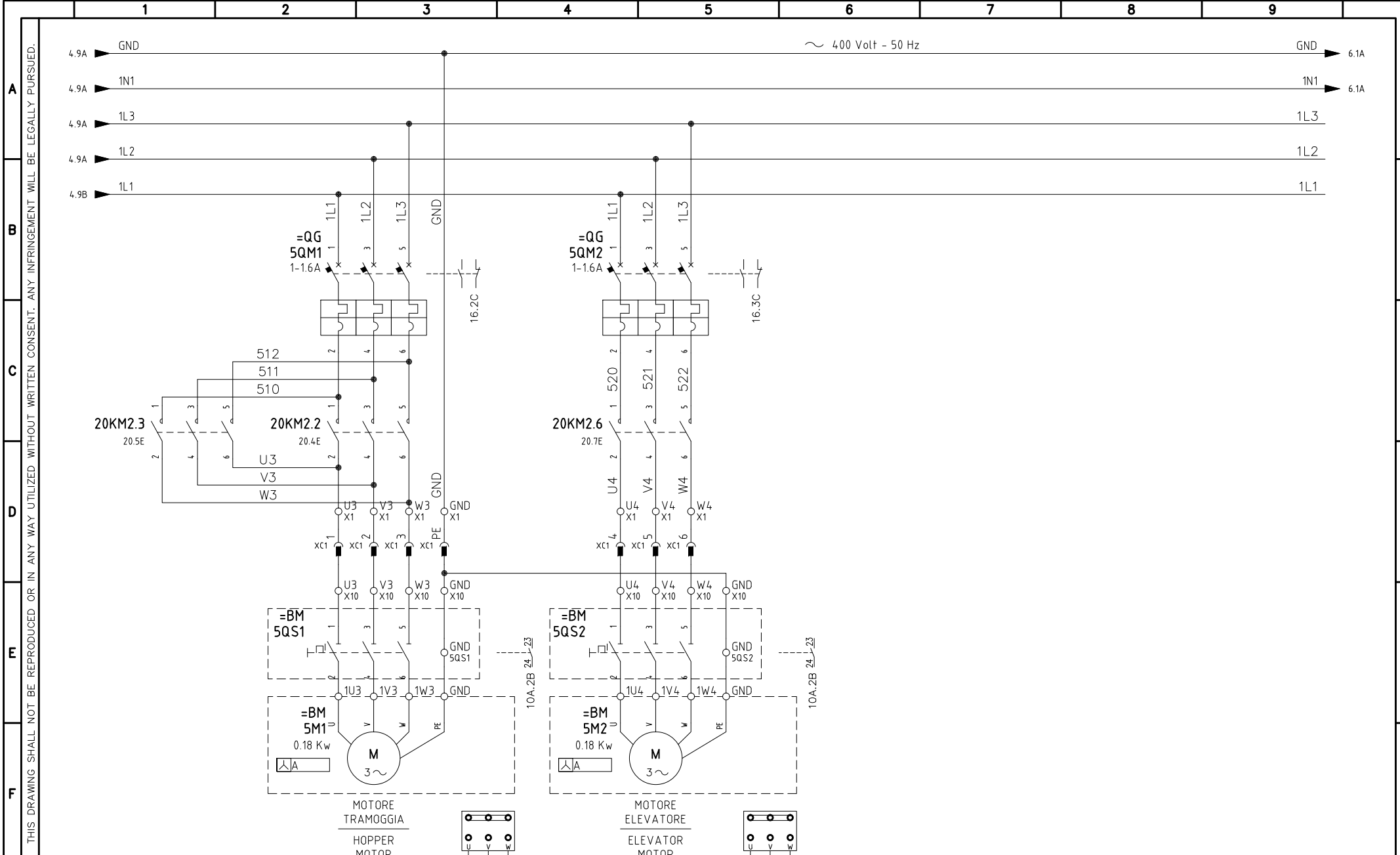



THIS DRAWING SHALL NOT BE REPRODUCED OR IN ANY WAY UTILIZED WITHOUT WRITTEN CONSENT. ANY INFRINGEMENT WILL BE LEGALLY PURSUED.

G	DISEGNATORE DESIGNER		IMPIANTO PLANT		SCHEMA ELETTRICO GESTIONE IMPIANTO ROTARY CAPS WIRING DIAGRAM PLANT GESTION ROTARY CAPS			CAD	SPAC	 bonino ®	
	NOME FILE FILE NAME		DATA REVISIONE REVISION DATE		REV. n° REV. nr°	COMMESSA ORDER	DATA DATE	DESCRIZIONE PAGINA PAGE DESCRIPTION	PAG.		DI OF
	SCHEMA N° DIAGRAM NR.		02/07/13		1	37016	11/01/2012	MOTORI MOTORS	5		38

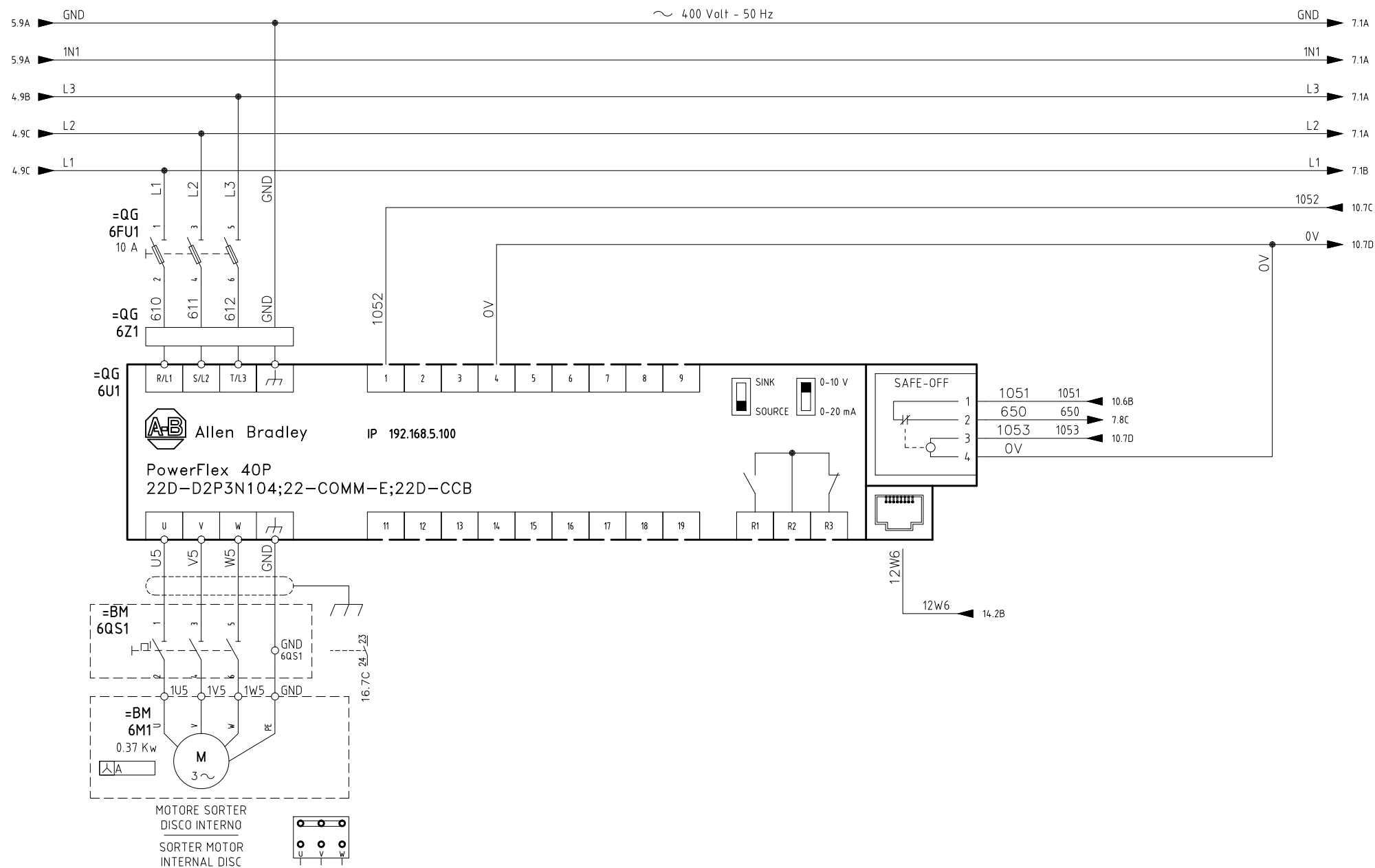
THIS DRAWING SHALL NOT BE REPRODUCED OR IN ANY WAY UTILIZED WITHOUT WRITTEN CONSENT. ANY INFRINGEMENT WILL BE LEGALLY PURSUED.



G	DISEGNATORE DESIGNER		IMPIANTO PLANT		SCHEMA ELETTRICO GESTIONE IMPIANTO ROTARY CAPS WIRING DIAGRAM PLANT GESTION ROTARY CAPS			CAD	SPAC	 bonino ®	
	NOME FILE FILE NAME		DATA REVISIONE REVISION DATE		REV. n° REV. nr°	COMMESSA ORDER	DATA DATE	DESCRIZIONE PAGINA PAGE DESCRIPTION	PAG.		DI OF
	SCHEMA N° DIAGRAM NR.		02/07/13		1	37016	11/01/2012	MOTORI MOTORS	6		38

THIS DRAWING SHALL NOT BE REPRODUCED OR IN ANY WAY UTILIZED WITHOUT WRITTEN CONSENT. ANY INFRINGEMENT WILL BE LEGALLY PURSUED.

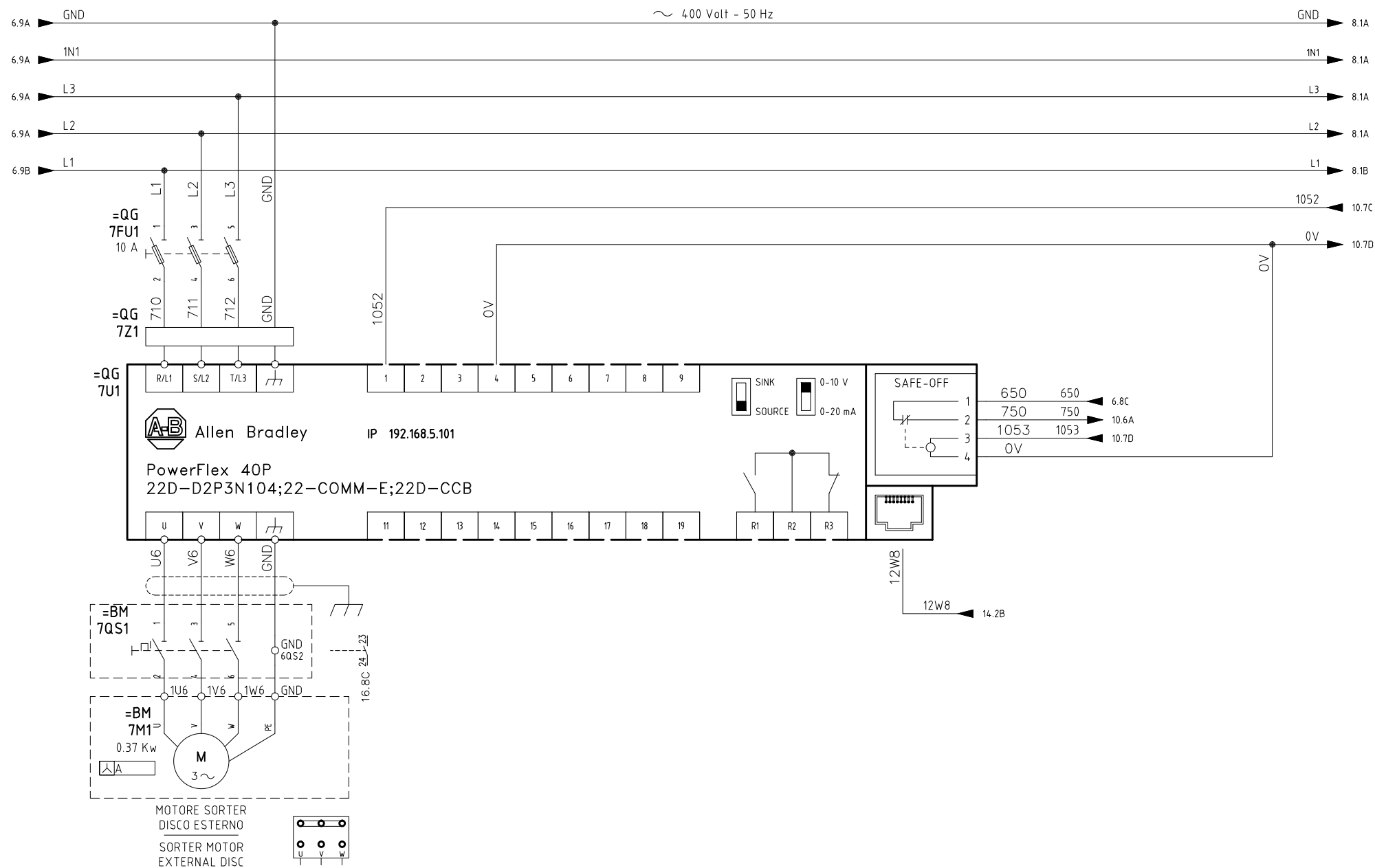

G	1	2	3	4	5	6	7	8	9	
	DISEGNATORE DESIGNER		IMPIANTO PLANT		SCHEMA ELETTRICO GESTIONE IMPIANTO ROTARY CAPS WIRING DIAGRAM PLANT GESTION ROTARY CAPS			CAD	SPAC	
	NOME FILE FILE NAME		DATA REVISIONE REVISION DATE		REV. n° REV. nr°	COMMESSA ORDER	DATA DATE	DESCRIZIONE PAGINA PAGE DESCRIPTION	PAG.	
SCHEMA N° DIAGRAM NR.		02/07/13		1	37016	11/01/2012	MOTORI MOTORS	7	38	

THIS DRAWING SHALL NOT BE REPRODUCED OR IN ANY WAY UTILIZED WITHOUT WRITTEN CONSENT. ANY INFRINGEMENT WILL BE LEGALLY PURSUED.

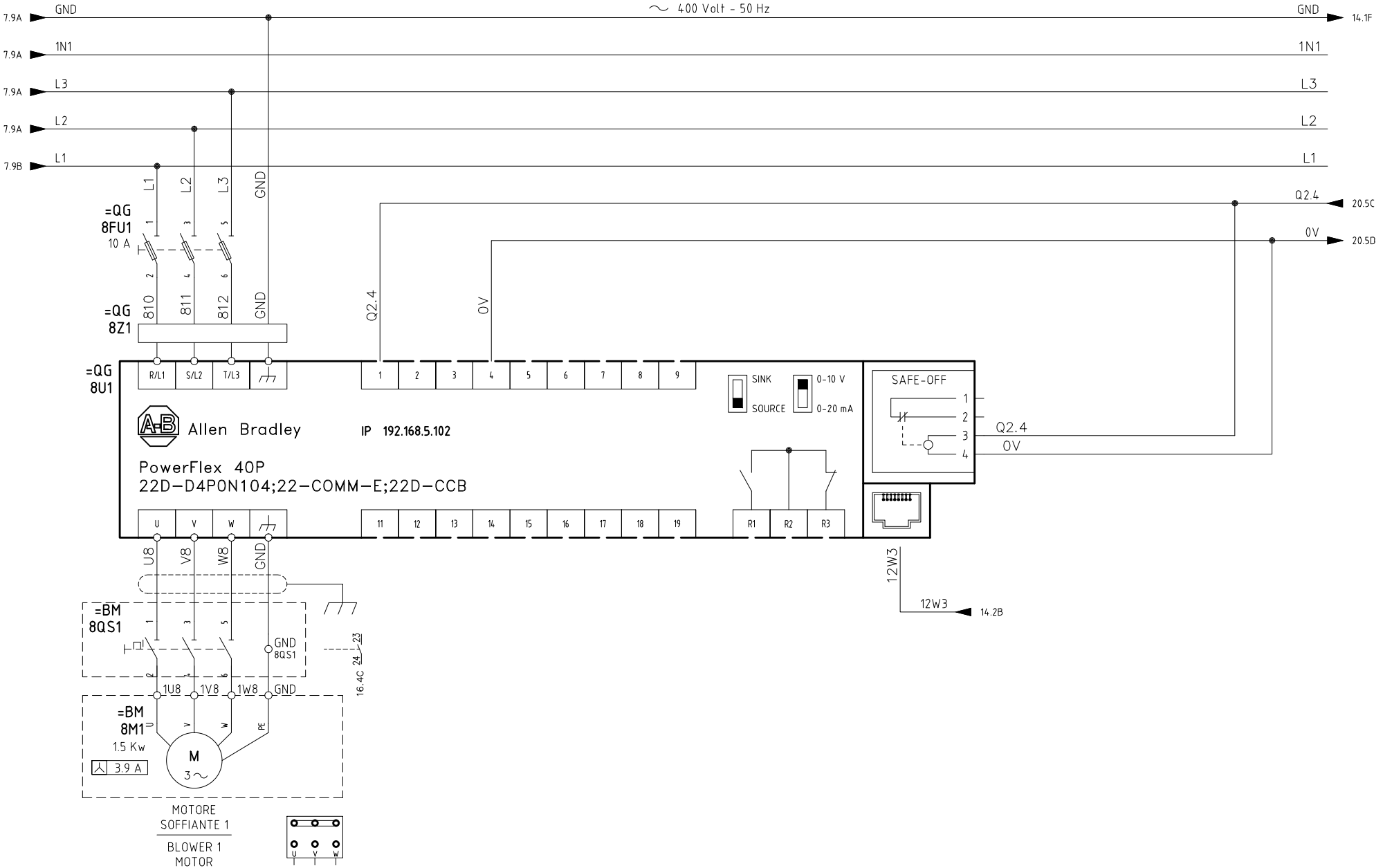

G	DISEGNATORE DESIGNER	FD	IMPIANTO PLANT	SCHEMA ELETTRICO GESTIONE IMPIANTO ROTARY CAPS WIRING DIAGRAM PLANT GESTION ROTARY CAPS				CAD	SPAC	
	NOME FILE FILE NAME	EKI_01388	DATA REVISIONE REVISION DATE	REV. n° REV. nr°	COMMESSA ORDER	DATA DATE	DESCRIZIONE PAGINA PAGE DESCRIPTION	PAG.	DI OF	
	SCHEMA N° DIAGRAM NR.	EKI_01388	02/07/13	1	37016	11/01/2012	MOTORI MOTORS	8	38	

THIS DRAWING SHALL NOT BE REPRODUCED OR IN ANY WAY UTILIZED WITHOUT WRITTEN CONSENT. ANY INFRINGEMENT WILL BE LEGALLY PURSUED.

22B-D2P3N104		6U1
IP 192.168.5.100		
PAR	DESCRIPTION	IMP.
P031	MOTOR TARGET VOLTAGE	480
P032	MOTOR TARGET FREQUENCY	60
P033	MOTOR TARGET CURRENT	---
P034	MIN FREQUENCY	0.00
P035	MAX FREQUENCY	100.00
P036	START SOURCE (Comm Port)	5
P037	STOP MODE (Ramp)	0
P038	SPEED REF (Comm Port)	5
P039	ACCELERATION 1	2.0
P040	DECELERATION 1	2.0
A051	DIGITAL INPUT 1 SELECT	0
A052	DIGITAL INPUT 2 SELECT	0
A053	DIGITAL INPUT 3 SELECT	0
A054	DIGITAL INPUT 4 SELECT	0
A067	ACCELERATION 2	2.0
A068	DECELERATION 2	0.5

22B-D2P3N104		7U1
IP 192.168.5.101		
PAR	DESCRIPTION	IMP.
P031	MOTOR TARGET VOLTAGE	480
P032	MOTOR TARGET FREQUENCY	60
P033	MOTOR TARGET CURRENT	---
P034	MIN FREQUENCY	0.00
P035	MAX FREQUENCY	100.00
P036	START SOURCE (Comm Port)	5
P037	STOP MODE (Ramp)	0
P038	SPEED REF (Comm Port)	5
P039	ACCELERATION 1	2.0
P040	DECELERATION 1	2.0
A051	DIGITAL INPUT 1 SELECT	0
A052	DIGITAL INPUT 2 SELECT	0
A053	DIGITAL INPUT 3 SELECT	0
A054	DIGITAL INPUT 4 SELECT	0
A067	ACCELERATION 2	2.0
A068	DECELERATION 2	0.3

22B-D2P3N104		8U1
IP 192.168.5.101		
PAR	DESCRIPTION	IMP.
P031	MOTOR TARGET VOLTAGE	480
P032	MOTOR TARGET FREQUENCY	60
P033	MOTOR TARGET CURRENT	---
P034	MIN FREQUENCY	0.00
P035	MAX FREQUENCY	100.00
P036	START SOURCE (Comm Port)	5
P037	STOP MODE (Ramp)	0
P038	SPEED REF (Comm Port)	5
P039	ACCELERATION 1	2.0
P040	DECELERATION 1	2.0
A051	DIGITAL INPUT 1 SELECT	0
A052	DIGITAL INPUT 2 SELECT	0
A053	DIGITAL INPUT 3 SELECT	0
A054	DIGITAL INPUT 4 SELECT	0
A067	ACCELERATION 2	2.0
A068	DECELERATION 2	0.3

<i>DISEGNATORE DESIGNER</i>	FD	<i>IMPIANTO PLANT</i>	SCHEMA ELETTRICO GESTIONE IMPIANTO ROTARY CAPS WIRING DIAGRAM PLANT GESTION ROTARY CAPS				<i>CAD</i>	SPAC
<i>NOME FILE FILE NAME</i>	EKI_01388	<i>DATA REVISIONE REVISION DATE</i>	<i>REV. n° REV. nr°</i>	<i>COMMESSA ORDER</i>	<i>DATA DATE</i>	<i>DESCRIZIONE PAGINA PAGE DESCRIPTION</i>	<i>PAG.</i>	<i>DI OF</i>
<i>SCHEMA N° DIAGRAM NR.</i>	EKI_01388	02/07/13	1	37016	11/01/2012	PARAMETRI INVERTER INVERTER PARAMETER	8A	38



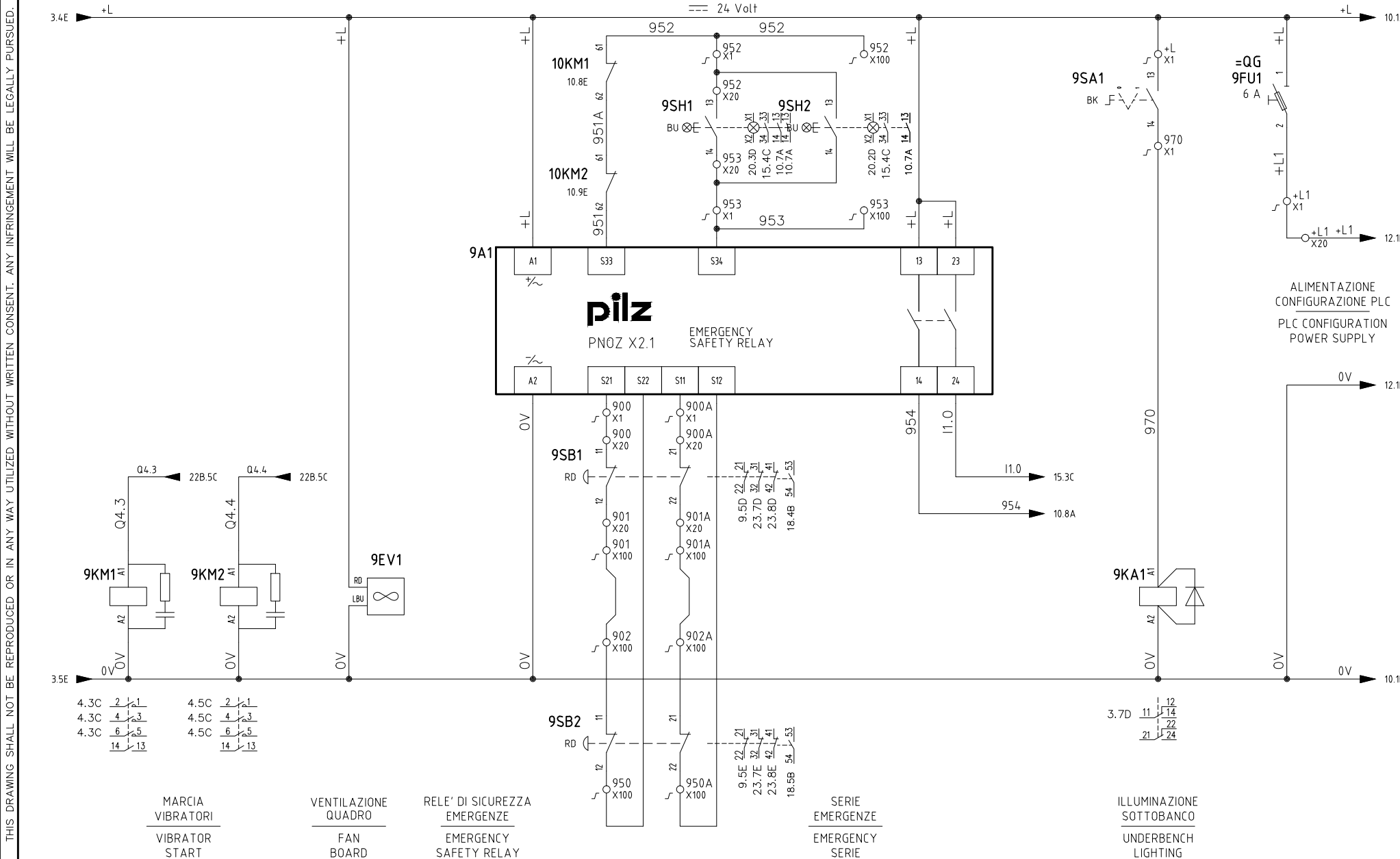

THIS DRAWING SHALL NOT BE REPRODUCED OR IN ANY WAY UTILIZED WITHOUT WRITTEN CONSENT. ANY INFRINGEMENT WILL BE LEGALLY PURSUED.

G	DISEGNATORE DESIGNER FD	IMPIANTO PLANT SCHEMA ELETTRICO GESTIONE IMPIANTO ROTARY CAPS WIRING DIAGRAM PLANT GESTION ROTARY CAPS	CAD SPAC						
	NOME FILE FILE NAME EKI_01388	DATA REVISIONE REVISION DATE 02/07/13	REV. n° REV. nr° 1		COMMESSA ORDER 37016	DATA DATE 11/01/2012	DESCRIZIONE PAGINA PAGE DESCRIPTION AUSILIARI AUXILIARY	PAG. 9	DI OF 38
	SCHEMA N° DIAGRAM NR. EKI_01388	02/07/13	1		37016	11/01/2012	AUSILIARI AUXILIARY	9	38

THIS DRAWING SHALL NOT BE REPRODUCED OR IN ANY WAY UTILIZED WITHOUT WRITTEN CONSENT. ANY INFRINGEMENT WILL BE LEGALLY PURSUED.

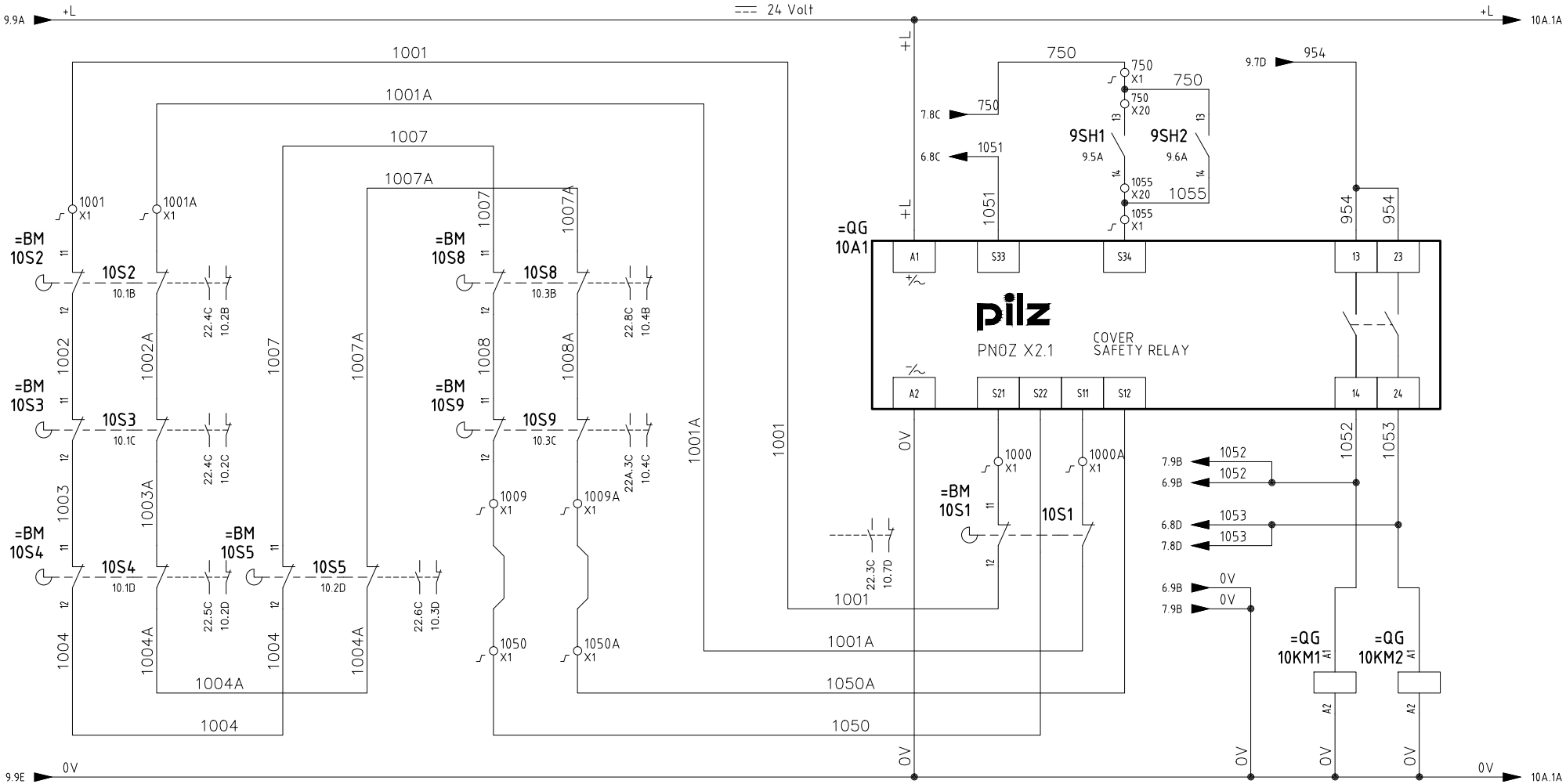

SERIE
RIPARI
COVER
SERIE

RELE' DI SICUREZZA
RIPARI
COVER
SAFETY RELAY

TELERUTTORE
GENERALE
GENERAL
CONTACTOR

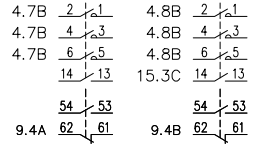

G	DISEGNATORE DESIGNER		IMPIANTO PLANT		SCHEMA ELETTRICO GESTIONE IMPIANTO ROTARY CAPS WIRING DIAGRAM PLANT GESTION ROTARY CAPS			CAD		SPAC		
	NOME FILE FILE NAME		DATA REVISIONE REVISION DATE		REV. n° REV. nr°	COMMESSA ORDER	DATA DATE	DESCRIZIONE PAGINA PAGE DESCRIPTION			PAG.	DI OF
	SCHEMA N° DIAGRAM NR.		02/07/13		1	37016	11/01/2012	AUSILIARI AUXILIARY			10	38



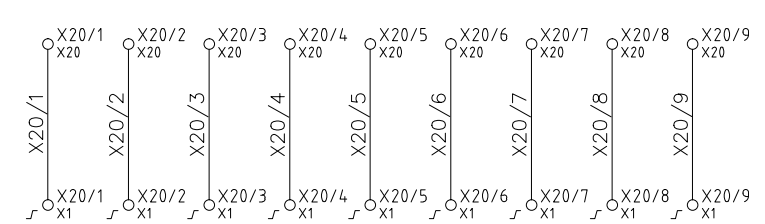
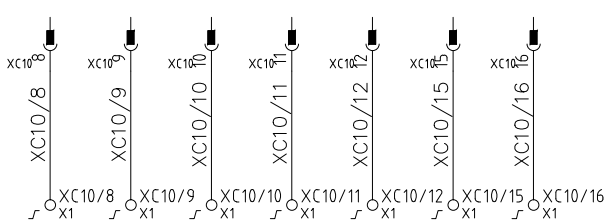
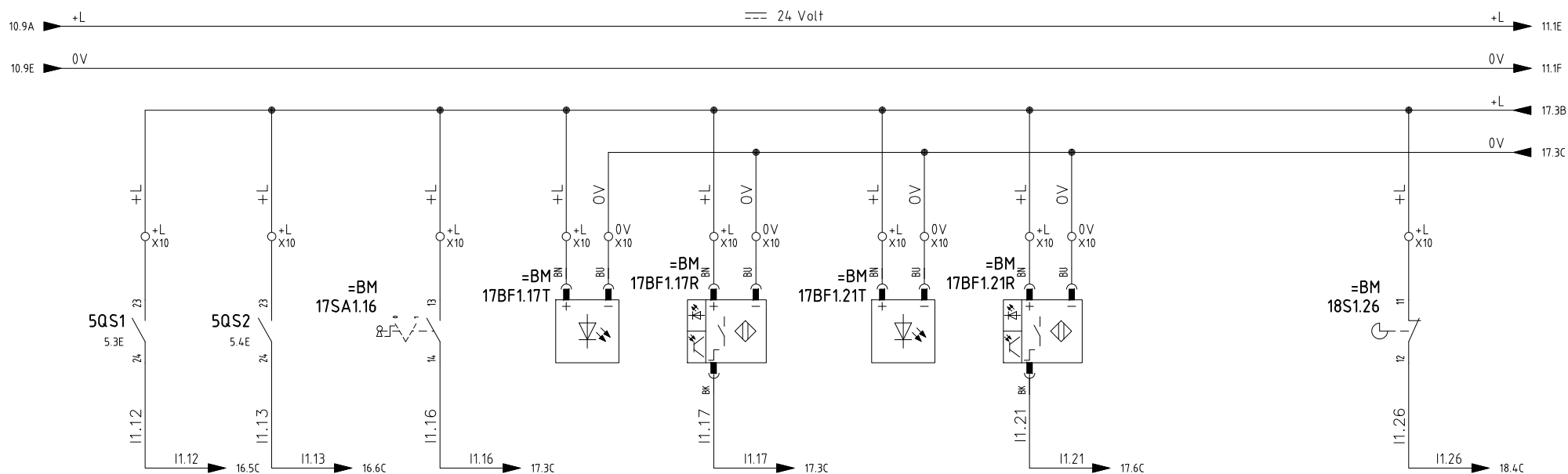

THIS DRAWING SHALL NOT BE REPRODUCED OR IN ANY WAY UTILIZED WITHOUT WRITTEN CONSENT. ANY INFRINGEMENT WILL BE LEGALLY PURSUED.

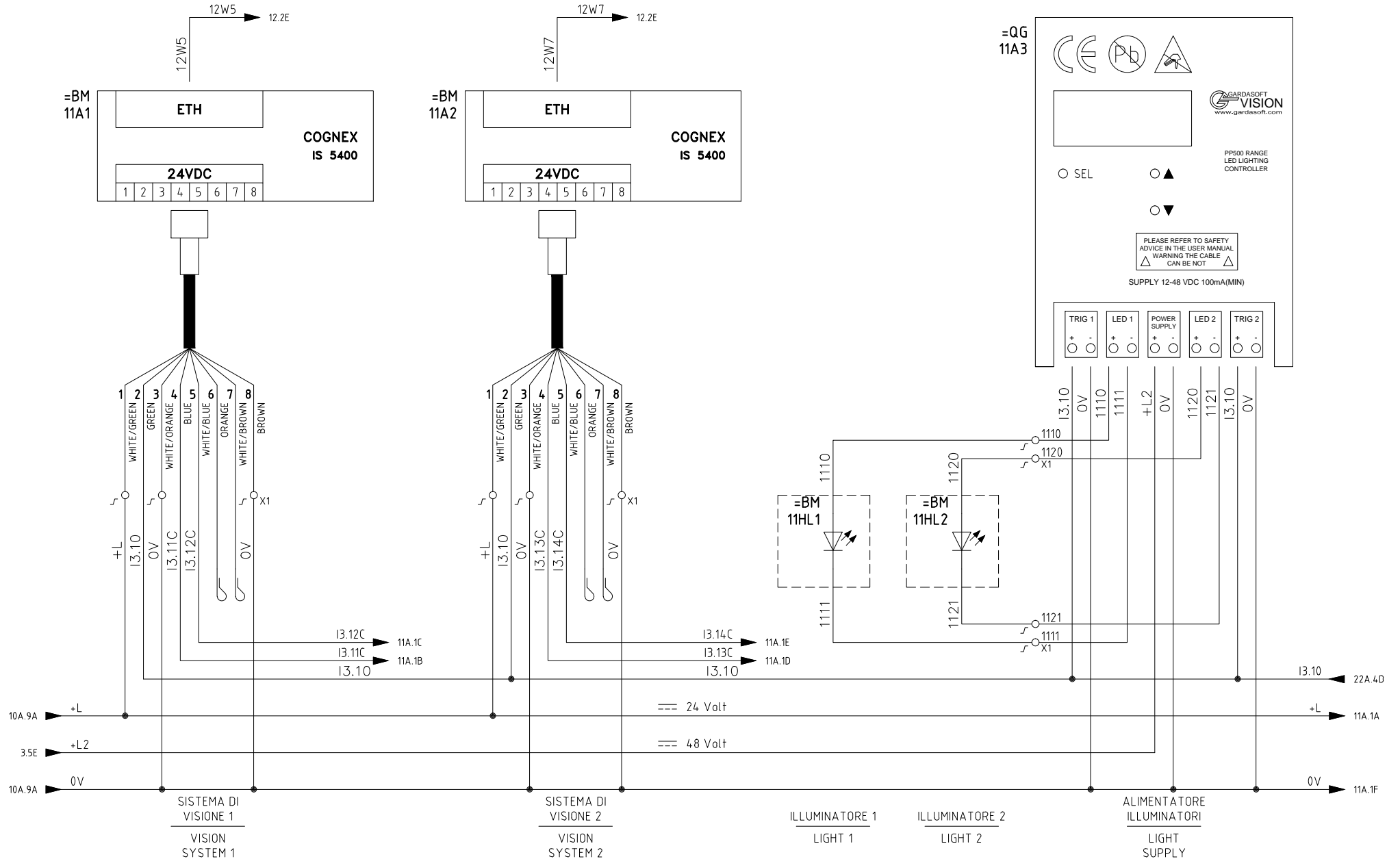

G	DISEGNATORE DESIGNER FD		IMPIANTO PLANT SCHEMA ELETTRICO GESTIONE IMPIANTO ROTARY CAPS WIRING DIAGRAM PLANT GESTION ROTARY CAPS		CAD SPAC					
	NOME FILE FILE NAME EKI_01388		DATA REVISIONE REVISION DATE 02/07/13		REV. n° REV. nr° 1				COMMESSA ORDER 37016	
	SCHEMA N° DIAGRAM NR. EKI_01388		DATA DATE 11/01/2012		DESCRIZIONE PAGINA PAGE DESCRIPTION AUSILIARI AUXILIARY				PAG. DI OF 10A 38	

THIS DRAWING SHALL NOT BE REPRODUCED OR IN ANY WAY UTILIZED WITHOUT WRITTEN CONSENT. ANY INFRINGEMENT WILL BE LEGALLY PURSUED.



G	DISEGNATORE DESIGNER	FD	IMPIANTO PLANT	SCHEMA ELETTRICO GESTIONE IMPIANTO ROTARY CAPS WIRING DIAGRAM PLANT GESTION ROTARY CAPS				CAD	SPAC	
	NOME FILE FILE NAME	EKI_01388	DATA REVISIONE REVISION DATE	REV. n° REV. nr°	COMMESSA ORDER	DATA DATE	DESCRIZIONE PAGINA PAGE DESCRIPTION	PAG.	DI OF	
	SCHEMA N° DIAGRAM NR.	EKI_01388	02/07/13	1	37016	11/01/2012	VISIONE VISION	11	38	

THIS DRAWING SHALL NOT BE REPRODUCED OR IN ANY WAY UTILIZED WITHOUT WRITTEN CONSENT. ANY INFRINGEMENT WILL BE LEGALLY PURSUED.

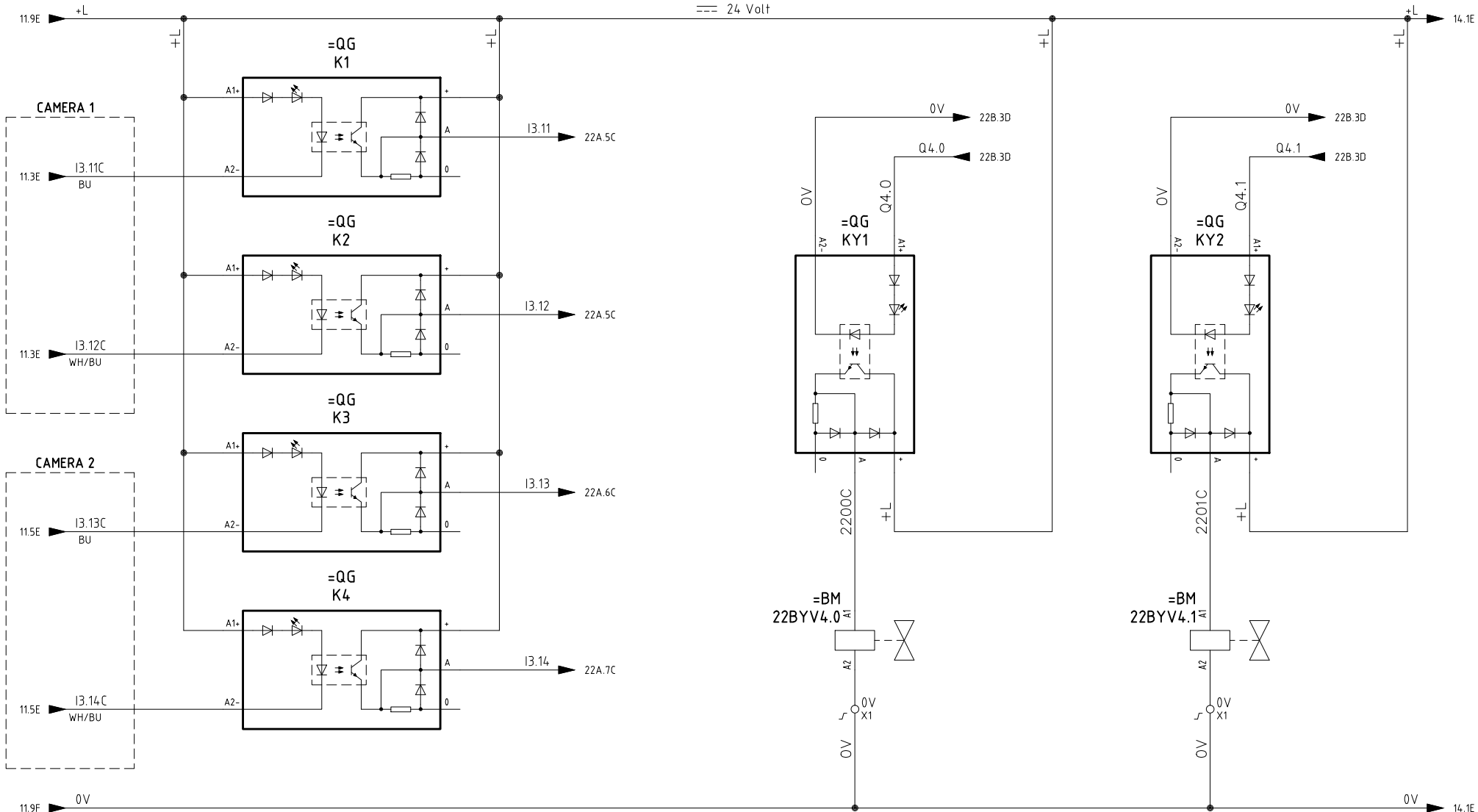

**DISEGNATORE
DESIGNER** FD

**NOME FILE
FILE NAME** EKI_01388

**SCHEMA N°
DIAGRAM NR.** EKI_01388

**IMPIANTO
PLANT** SCHEMA ELETTRICO GESTIONE IMPIANTO ROTARY CAPS
WIRING DIAGRAM PLANT GESTION ROTARY CAPS

**DATA REVISIONE
REVISION DATE** 02/07/13

**REV. n°
REV. nr°** 1

**COMMESSA
ORDER** 37016

**DATA
DATE** 11/01/2012

**DESCRIZIONE PAGINA
PAGE DESCRIPTION** VISIONE
VISION

CAD SPAC

PAG. 11A

**DI
OF** 38



THIS DRAWING SHALL NOT BE REPRODUCED OR IN ANY WAY UTILIZED WITHOUT WRITTEN CONSENT. ANY INFRINGEMENT WILL BE LEGALLY PURSUED.

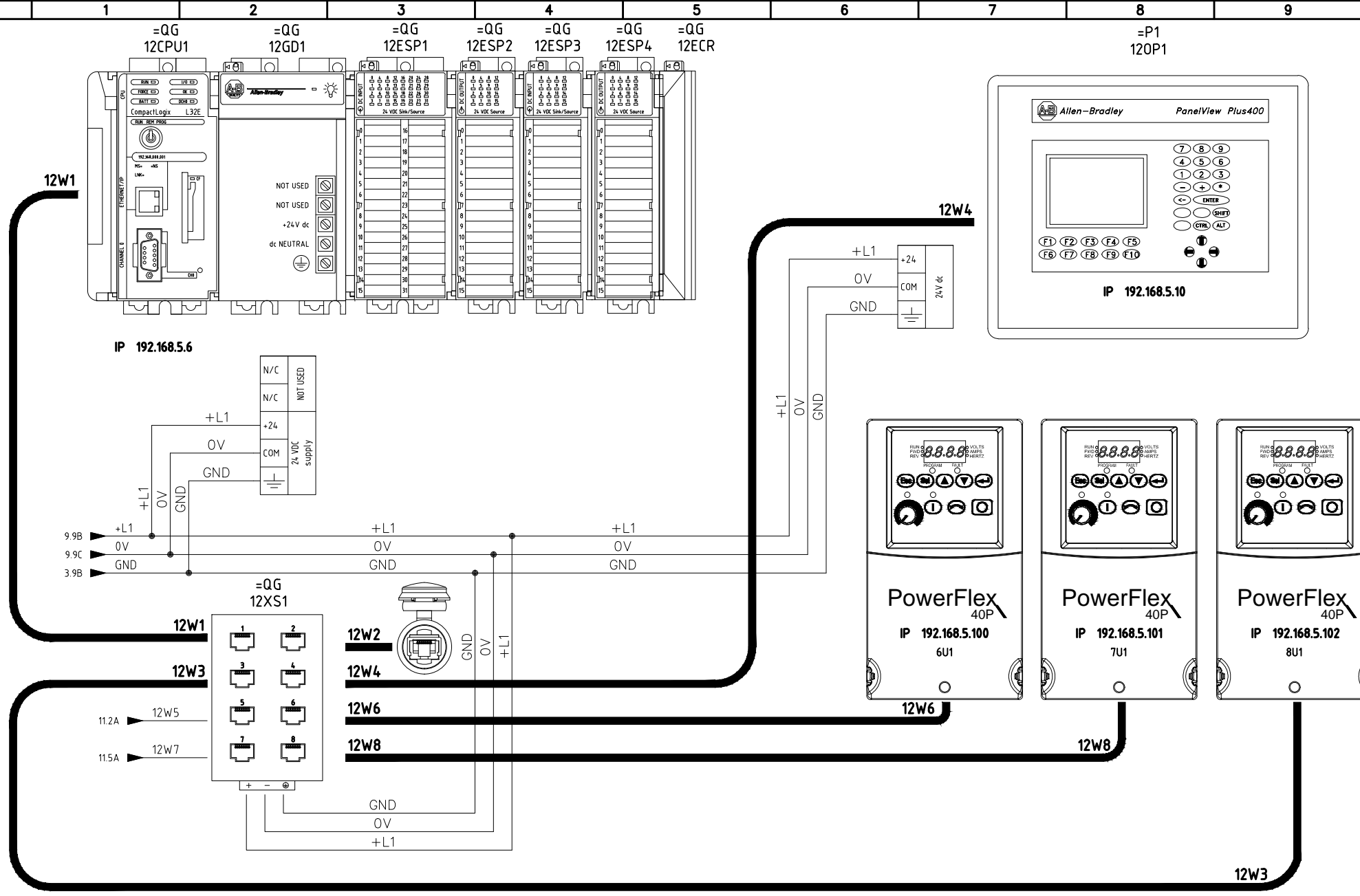

G	DISEGNATORE DESIGNER	FD	IMPIANTO PLANT	SCHEMA ELETTRICO GESTIONE IMPIANTO ROTARY CAPS WIRING DIAGRAM PLANT GESTION ROTARY CAPS			CAD	SPAC	 bonino ®
	NOME FILE FILE NAME	EKI_01388	DATA REVISIONE REVISION DATE	REV. n° REV. nr°	COMMESSA ORDER	DATA DATE	DESCRIZIONE PAGINA PAGE DESCRIPTION	PAG. DI OF	
	SCHEMA N° DIAGRAM NR.	EKI_01388	02/07/13	1	37016	11/01/2012	PLC PLC	12 38	

THIS DRAWING SHALL NOT BE REPRODUCED OR IN ANY WAY UTILIZED WITHOUT WRITTEN CONSENT. ANY INFRINGEMENT WILL BE LEGALLY PURSUED.

Panel: =QG Cpu: 12ESP1
 Mod.: 0
 DC INPUT
 Type: 1769-IQ32

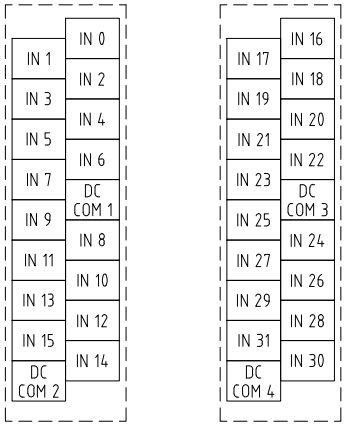

INPUT			
Pin	Bit	Description	Sheet
IN 0	I1.0	AUSILIARI INSERITI	
IN 1	I1.1	PILZ RIPARI OK	
IN 2	I1.2	RESET	
IN 3	I1.3	MARCIA	
IN 4	I1.4	ARRESTO	
IN 5	I1.5	SELETTORE JOG	
IN 6	I1.6	SELETTORE CAMBIO FORMATO	
IN 7	I1.7	MARCIA TRASPORTO	
DC COM 1		DC COM	
IN 8	I1.8	SCATTO TERMICO	
IN 9	I1.9	PULSANTE JOG	
IN 10	I1.10	SEZIONATORE SOFFIANTE 1	
IN 11	I1.11	SEZIONATORE SOFFIANTE 2	
IN 12	I1.12	SEZIONATORE TRAMOGGIA	
IN 13	I1.13	SEZIONATORE ELEVATORE	
IN 14	I1.14	SEZIONATORE SORTER DISCO INTERNO	
IN 15	I1.15	SEZIONATORE SORTER DISCO ESTERNO	
DC COM 2		DC COM	

INPUT			
Pin	Bit	Description	Sheet
IN 16	I1.16	SVUOTAMENTO TRAMOGGIA	
IN 17	I1.17	LIVELLO ELEVATORE	
IN 18	I1.18	LIVELLO SORTER	
IN 19	I1.19	LIVELLO MINIMO TRASPORTO	
IN 20	I1.20	LIVELLO MASSIMO TRASPORTO	
IN 21	I1.21	LIVELLO MINIMO TRAMOGGIA	
IN 22	I1.22	PRESSOSTATO	
IN 23	I1.23	CONTROLLO ROTAZIONE	
DC COM 3		DC COM	
IN 24	I1.24		
IN 25	I1.25	EMERGENZA PREMUTA	
IN 26	I1.26	SPORTELLO SVUOTAMENTO	
IN 27	I1.27		
IN 28	I1.28		
IN 29	I1.29		
IN 30	I1.30		
IN 31	I1.31	ABILITAZIONE ESTERNA	
DC COM 4		DC COM	

Panel: =QG Cpu: 12ESP3
 Mod.: 0
 DC INPUT
 Type: 1769-IQ16

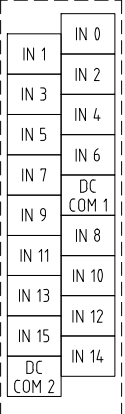

INPUT			
Pin	Bit	Description	Sheet
IN 0	I3.0	RIPARO LATERALE SORTER	
IN 1	I3.1	RIPARO 1 CAPP	
IN 2	I3.2	RIPARO 2 CAPP	
IN 3	I3.3	RIPARO 3 CAPP	
IN 4	I3.4	RIPARO 4 CAPP	
IN 5	I3.5		
IN 6	I3.6		
IN 7	I3.7	RIPARO 7 CAPP	
DC COM 1		DC COM	
IN 8	I3.8	RIPARO 8 CAPP	
IN 9	I3.9		
IN 10	I3.10	TRIGGER VISIONE	
IN 11	I3.11	VISIONE 1 READY	
IN 12	I3.12	VISIONE 1 BUONA	
IN 13	I3.13	VISIONE 2 READY	
IN 14	I3.14	VISIONE 2 BUONA	
IN 15	I3.15		
DC COM 2		DC COM	

DISEGNATORE DESIGNER	FD
NOME FILE FILE NAME	EKI_01388
SCHEMA N° DIAGRAM NR.	EKI_01388

IMPIANTO PLANT	SCHEMA ELETTRICO GESTIONE IMPIANTO ROTARY CAPS WIRING DIAGRAM PLANT GESTION ROTARY CAPS					CAD	SPAC
DATA REVISIONE REVISION DATE	REV. n° REV. nr°	COMMESSA ORDER	DATA DATE	DESCRIZIONE PAGINA PAGE DESCRIPTION		PAG.	DI OF
	02/07/13	1	37016	11/01/2012	PLC PLC	13	38



THIS DRAWING SHALL NOT BE REPRODUCED OR IN ANY WAY UTILIZED WITHOUT WRITTEN CONSENT. ANY INFRINGEMENT WILL BE LEGALLY PURSUED.

Panel: =QG	Cpu: 12ESP2
Mod.: 0	
 DC OUTPUT	
Type: 1769-OB16	

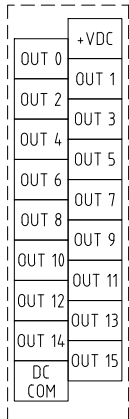

OUTPUT			
Pin	Bit	Description	Sheet
+VDC		+DC	
OUT 0	Q2.0	SPIA RESET	
OUT 1	Q2.1	SPIA MARCIA	
OUT 2	Q2.2	MARCIA TRAMOGGIA	
OUT 3	Q2.3	INDIETRO TRAMOGGIA	
OUT 4	Q2.4	MARCIA SOFFIANTE 1	
OUT 5	Q2.5	MARCIA SOFFIANTE 2	
OUT 6	Q2.6	MARCIA ELEVATORE	
OUT 7	Q2.7		
OUT 8	Q2.8	LAMPALLARME SUONERIA	
OUT 9	Q2.9	LAMPALLARME VERDE	
OUT 10	Q2.10	LAMPALLARME GIALLO	
OUT 11	Q2.11	LAMPALLARME ROSSO	
OUT 12	Q2.12	LAMPALLARME BLU	
OUT 13	Q2.13	EV GENERALE	
OUT 14	Q2.14		
OUT 15	Q2.15	EV SELEZIONE	
DC COM		-DC	

Panel: =QG	Cpu: 12ESP4
Mod.: 0	
 DC OUTPUT	
Type: 1769-OB16	

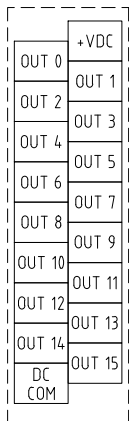

OUTPUT			
Pin	Bit	Description	Sheet
+VDC		+DC	
OUT 0	Q4.0	EV SCARTO VISIONE 1	
OUT 1	Q4.1	EV SCARTO VISIONE 2	
OUT 2	Q4.2		
OUT 3	Q4.3	MARCIA VIBRATORE 1	
OUT 4	Q4.4	MARCIA VIBRATORE 2	
OUT 5	Q4.5		
OUT 6	Q4.6		
OUT 7	Q4.7		
OUT 8	Q4.8		
OUT 9	Q4.9		
OUT 10	Q4.10		
OUT 11	Q4.11		
OUT 12	Q4.12		
OUT 13	Q4.13		
OUT 14	Q4.14		
OUT 15	Q4.15		
DC COM		-DC	

DISEGNATORE DESIGNER	FD	IMPIANTO PLANT	SCHEMA ELETTRICO GESTIONE IMPIANTO ROTARY CAPS WIRING DIAGRAM PLANT GESTION ROTARY CAPS				CAD	SPAC	 bonino®
NOME FILE FILE NAME	EKI_01388	DATA REVISIONE REVISION DATE	REV. n° REV. nr°	COMMESSA ORDER	DATA DATE	DESCRIZIONE PAGINA PAGE DESCRIPTION	PAG.	DI OF	
SCHEMA N° DIAGRAM NR.	EKI_01388	02/07/13	1	37016	11/01/2012	PLC PLC	13A	38	

THIS DRAWING SHALL NOT BE REPRODUCED OR IN ANY WAY UTILIZED WITHOUT WRITTEN CONSENT. ANY INFRINGEMENT WILL BE LEGALLY PURSUED.

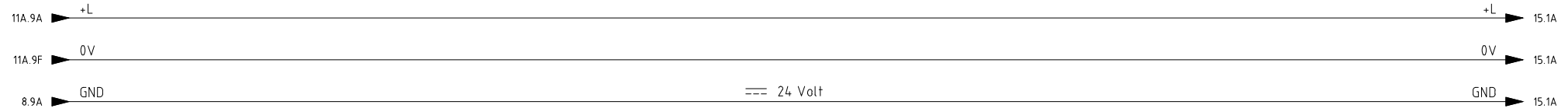
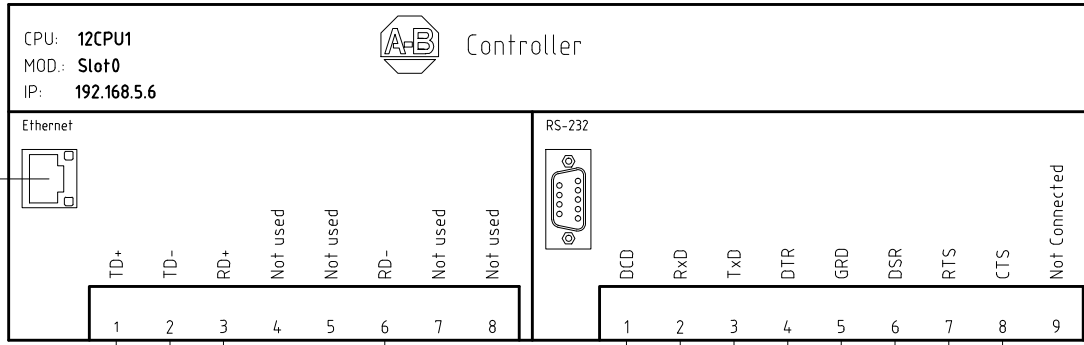

G	DISEGNATORE DESIGNER	FD	IMPIANTO PLANT	SCHEMA ELETTRICO GESTIONE IMPIANTO ROTARY CAPS WIRING DIAGRAM PLANT GESTION ROTARY CAPS				CAD	SPAC	
	NOME FILE FILE NAME	EKI_01388	DATA REVISIONE REVISION DATE	REV. n° REV. nr°	COMMESSA ORDER	DATA DATE	DESCRIZIONE PAGINA PAGE DESCRIPTION	PAG.	DI OF	
	SCHEMA N° DIAGRAM NR.	EKI_01388	02/07/13	1	37016	11/01/2012	PLC PLC	14	38	

THIS DRAWING SHALL NOT BE REPRODUCED OR IN ANY WAY UTILIZED WITHOUT WRITTEN CONSENT. ANY INFRINGEMENT WILL BE LEGALLY PURSUED.

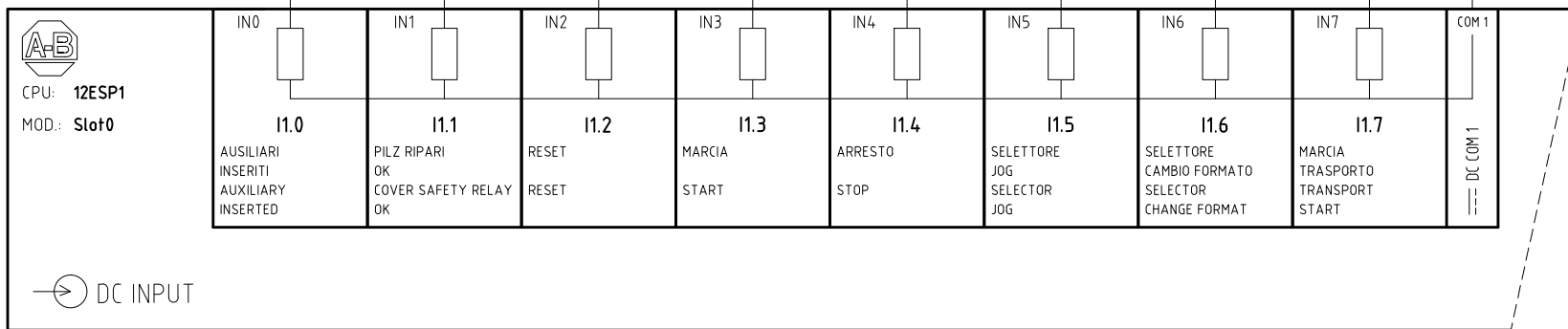
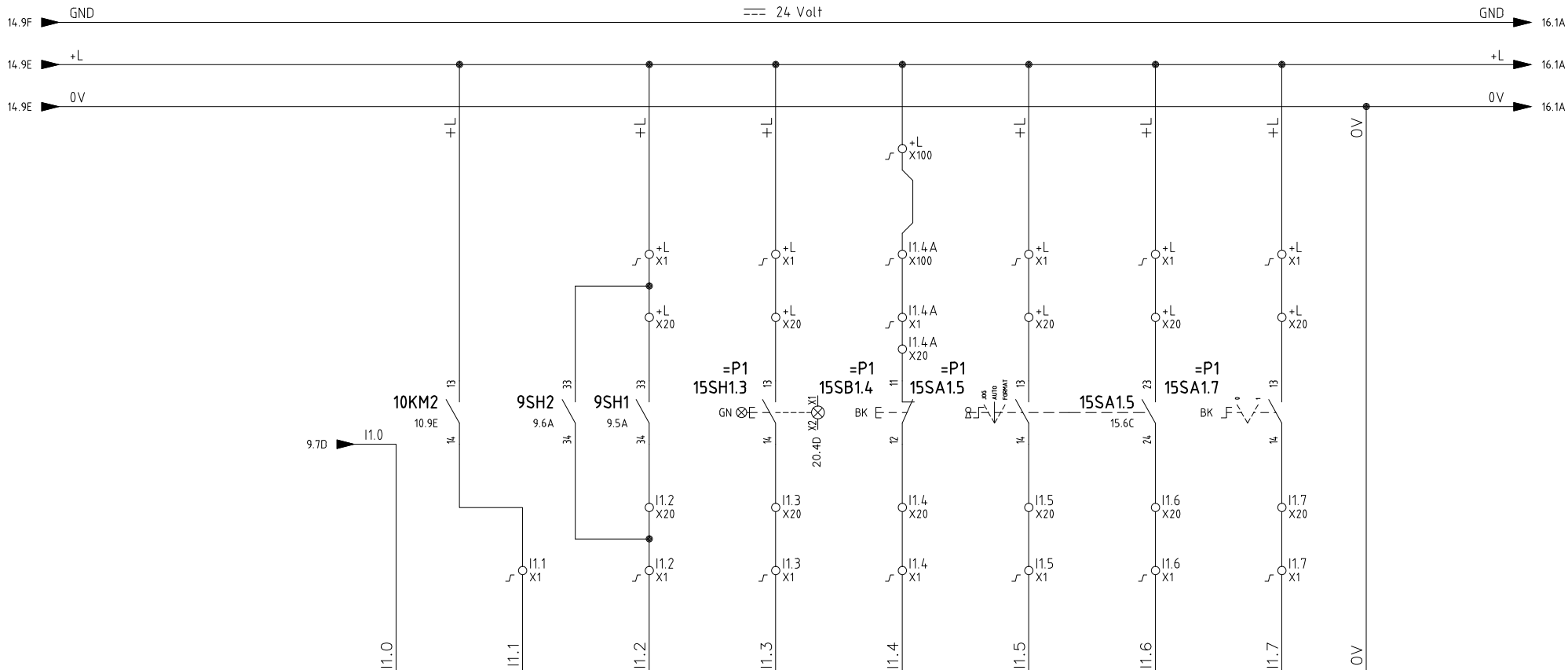

DISEGNATORE
DESIGNER

FD

IMPIANTO
PLANT

SCHEMA ELETTRICO GESTIONE IMPIANTO ROTARY CAPS
WIRING DIAGRAM PLANT GESTION ROTARY CAPS

CAD

SPAC

NOME FILE
FILE NAME

EKI_01388

DATA REVISIONE
REVISION DATE

REV. n°
REV. nr°

COMMESSA
ORDER

DATA
DATE

DESCRIZIONE PAGINA
PAGE DESCRIPTION

PAG.

DI
OF

SCHEMA N°
DIAGRAM NR.

EKI_01388

02/07/13

1

37016

11/01/2012

INGRESSI
INPUT

15

38



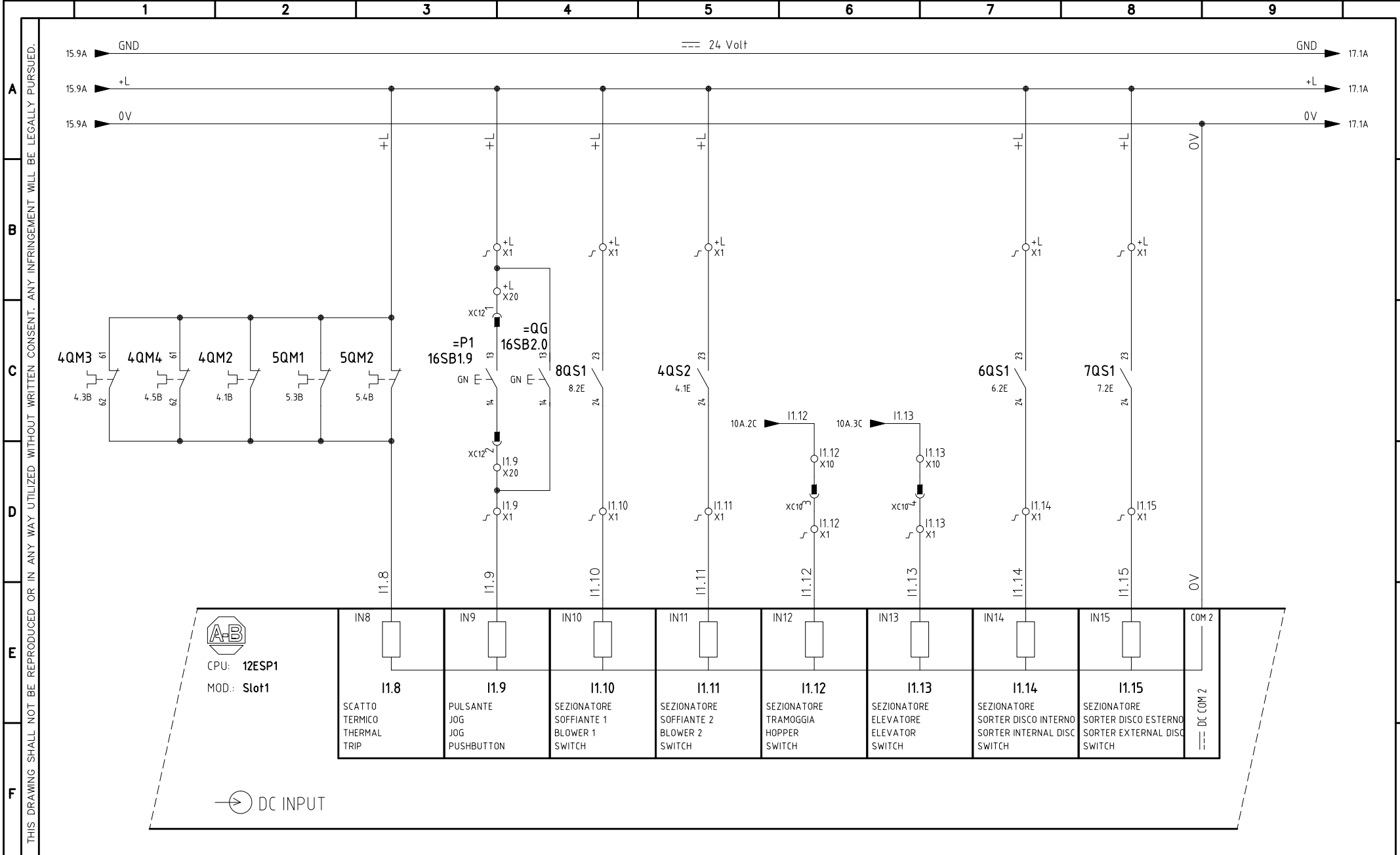

G	DISEGNATORE DESIGNER	FD	IMPIANTO PLANT	SCHEMA ELETTRICO GESTIONE IMPIANTO ROTARY CAPS WIRING DIAGRAM PLANT GESTION ROTARY CAPS				CAD	SPAC	
	NOME FILE FILE NAME	EKI_01388	DATA REVISIONE REVISION DATE	REV. n° REV. nr°	COMMESSA ORDER	DATA DATE	DESCRIZIONE PAGINA PAGE DESCRIPTION	PAG.	DI OF	
	SCHEMA N° DIAGRAM NR.	EKI_01388	02/07/13	1	37016	11/01/2012	INGRESSI INPUT	16	38	

THIS DRAWING SHALL NOT BE REPRODUCED OR IN ANY WAY UTILIZED WITHOUT WRITTEN CONSENT. ANY INFRINGEMENT WILL BE LEGALLY PURSUED.

THIS DRAWING SHALL NOT BE REPRODUCED OR IN ANY WAY UTILIZED WITHOUT WRITTEN CONSENT. ANY INFRINGEMENT WILL BE LEGALLY PURSUED.

THIS DRAWING SHALL NOT BE REPRODUCED OR IN ANY WAY UTILIZED WITHOUT WRITTEN CONSENT. ANY INFRINGEMENT WILL BE LEGALLY PURSUED.

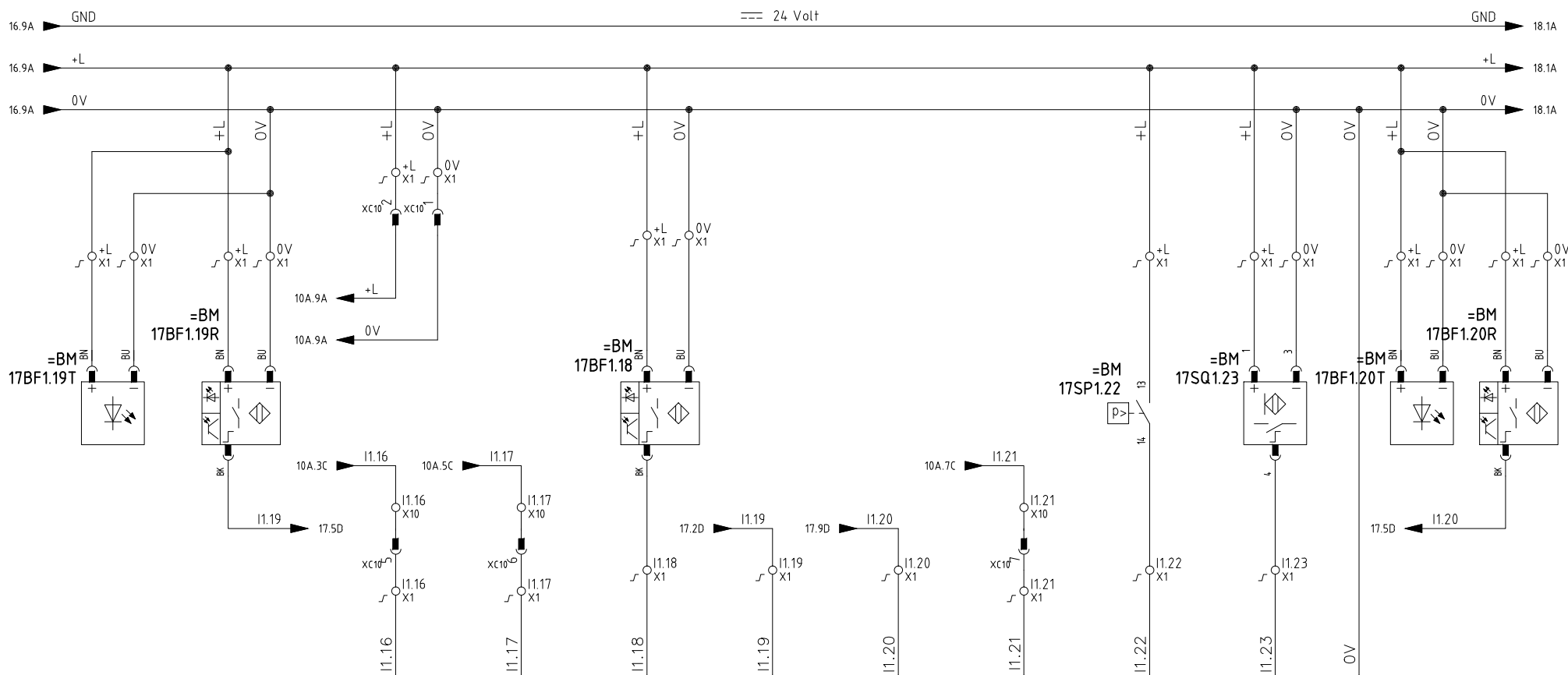

<p>CPU: 12ESP1 MOD.: Slot2</p>	IN16	IN17	IN18	IN19	IN20	IN21	IN22	IN23	COM 3
	I1.16 SVUOTAMENTO TRAMOGGIA HOPPER EMPTYING	I1.17 LIVELLO ELEVATORE ELEVATOR LEVEL	I1.18 LIVELLO SORTER SORTER LEVEL	I1.19 LIVELLO MINIMO TRASPORTO MIN LEVEL TRANSPORT	I1.20 LIVELLO MASSIMO TRASPORTO MAX LEVEL TRANSPORT	I1.21 LIVELLO MINIMO TRAMOGGIA HOPPER MIN LEVEL	I1.22 PRESSOSTATO PRESSURE SWITCH	I1.23 CONTROLLO ROTAZIONE ROTATION CONTROL	DC COM 3

DC INPUT

G	DISEGNATORE DESIGNER	FD	IMPIANTO PLANT	SCHEMA ELETTRICO GESTIONE IMPIANTO ROTARY CAPS WIRING DIAGRAM PLANT GESTION ROTARY CAPS				CAD	SPAC	
	NOME FILE FILE NAME	EKI_01388	DATA REVISIONE REVISION DATE	REV. n° REV. nr°	COMMESSA ORDER	DATA DATE	DESCRIZIONE PAGINA PAGE DESCRIPTION	PAG.	DI OF	
	SCHEMA N° DIAGRAM NR.	EKI_01388	02/07/13	1	37016	11/01/2012	INGRESSI INPUT	17	38	

THIS DRAWING SHALL NOT BE REPRODUCED OR IN ANY WAY UTILIZED WITHOUT WRITTEN CONSENT. ANY INFRINGEMENT WILL BE LEGALLY PURSUED.

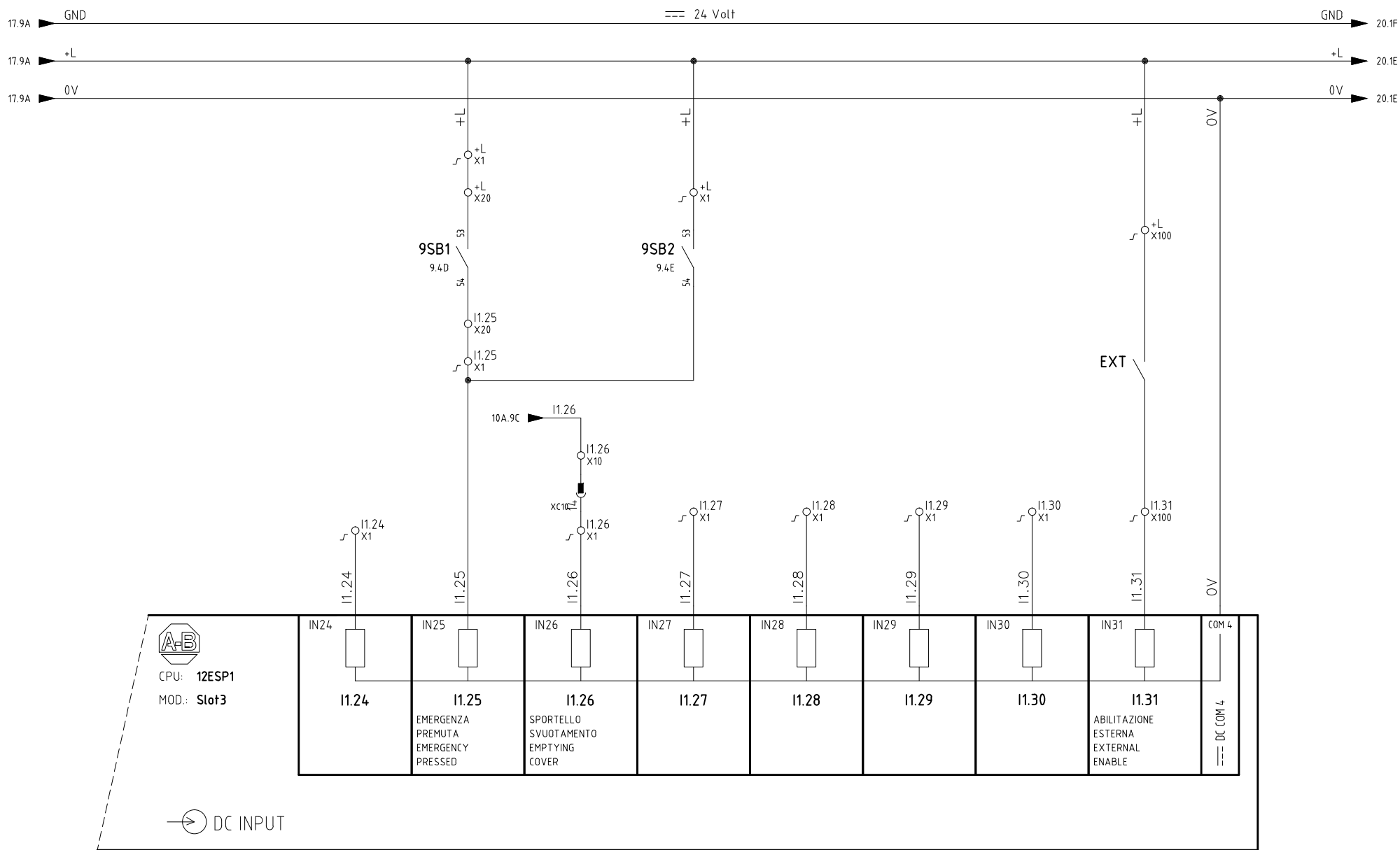

G	DISEGNATORE DESIGNER		IMPIANTO PLANT		SCHEMA ELETTRICO GESTIONE IMPIANTO ROTARY CAPS WIRING DIAGRAM PLANT GESTION ROTARY CAPS			CAD		SPAC	
	NOME FILE FILE NAME		DATA REVISIONE REVISION DATE		REV. n° REV. nr°	COMMESSA ORDER	DATA DATE	DESCRIZIONE PAGINA PAGE DESCRIPTION		PAG.	DI OF
	SCHEMA N° DIAGRAM NR.		02/07/13		1	37016	11/01/2012	INGRESSI INPUT		18	38



THIS DRAWING SHALL NOT BE REPRODUCED OR IN ANY WAY UTILIZED WITHOUT WRITTEN CONSENT. ANY INFRINGEMENT WILL BE LEGALLY PURSUED.

A

B

C

D

E

F

G

1

2

3

4

5

6

7

8

9

A

B

C

D

E

F

G

<i>DISEGNATORE DESIGNER</i>	FD	<i>IMPIANTO PLANT</i>	SCHEMA ELETTRICO GESTIONE IMPIANTO ROTARY CAPS WIRING DIAGRAM PLANT GESTION ROTARY CAPS				<i>CAD</i>	SPAC	 bonino [®]
<i>NOME FILE FILE NAME</i>	EKI_01388	<i>DATA REVISIONE REVISION DATE</i>	<i>REV. n° REV. nr°</i>	<i>COMMESSA ORDER</i>	<i>DATA DATE</i>	<i>DESCRIZIONE PAGINA PAGE DESCRIPTION</i>	<i>PAG.</i>	<i>DI OF</i>	
<i>SCHEMA N° DIAGRAM NR.</i>	EKI_01388	02/07/13	1	37016	11/01/2012		19	38	

1

2

3

4

5

6

7

8

9

THIS DRAWING SHALL NOT BE REPRODUCED OR IN ANY WAY UTILIZED WITHOUT WRITTEN CONSENT. ANY INFRINGEMENT WILL BE LEGALLY PURSUED.

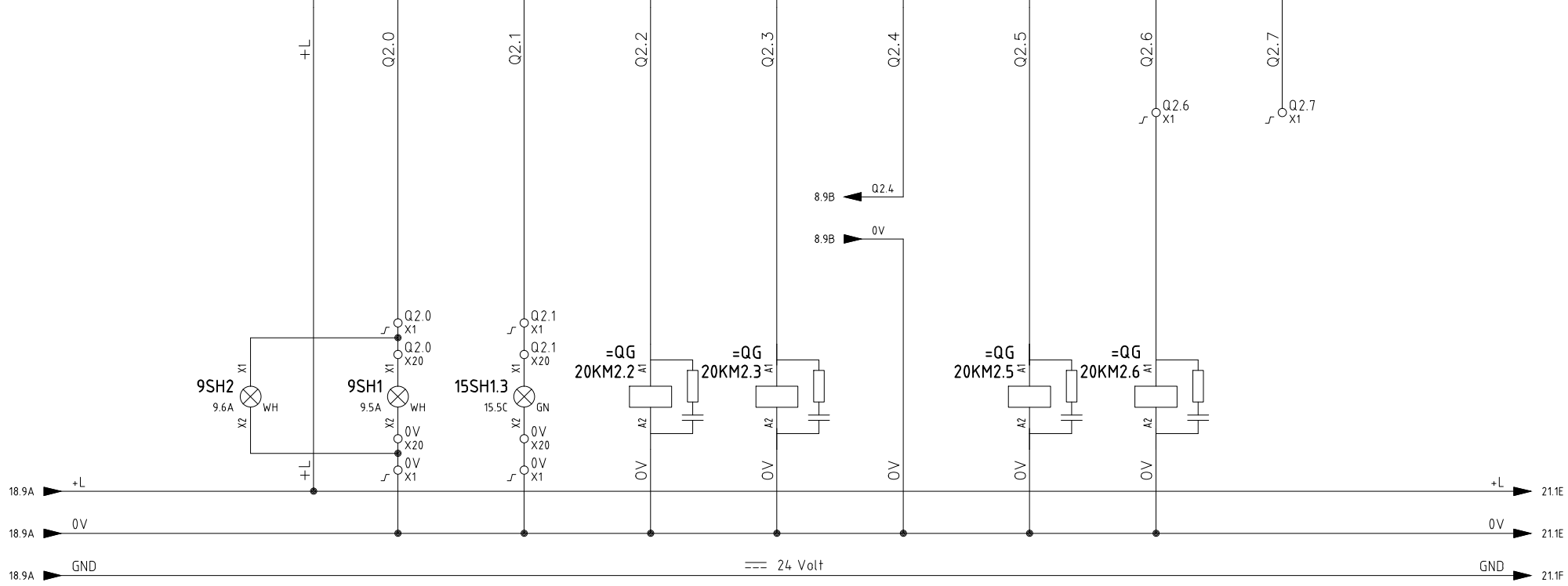
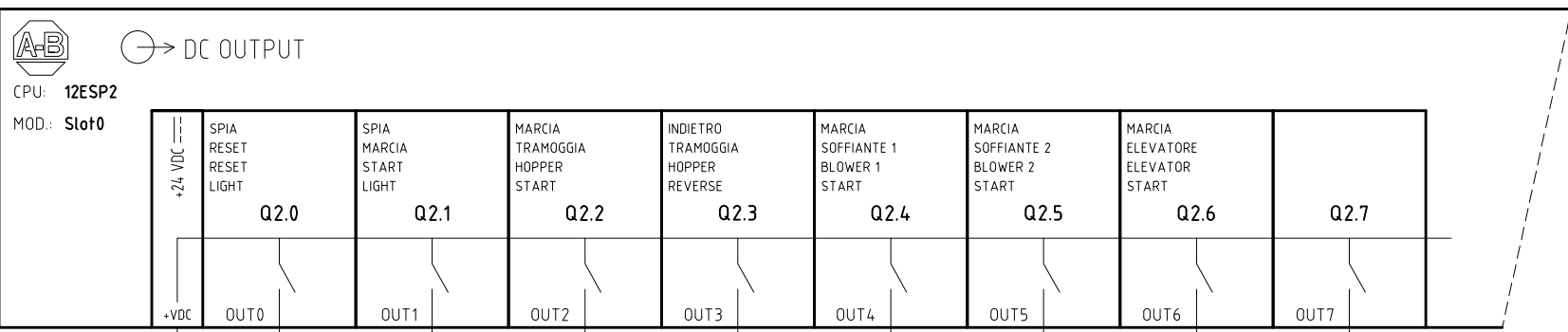

G	DISEGNATORE DESIGNER	FD	IMPIANTO PLANT	SCHEMA ELETTRICO GESTIONE IMPIANTO ROTARY CAPS WIRING DIAGRAM PLANT GESTION ROTARY CAPS				CAD	SPAC	
	NOME FILE FILE NAME	EKI_01388	DATA REVISIONE REVISION DATE	REV. n° REV. nr°	COMMESSA ORDER	DATA DATE	DESCRIZIONE PAGINA PAGE DESCRIPTION	PAG.	DI OF	
	SCHEMA N° DIAGRAM NR.	EKI_01388	02/07/13	1	37016	11/01/2012	USCITE OUTPUT	20	38	

THIS DRAWING SHALL NOT BE REPRODUCED OR IN ANY WAY UTILIZED WITHOUT WRITTEN CONSENT. ANY INFRINGEMENT WILL BE LEGALLY PURSUED.



⊖ → DC OUTPUT

CPU: 12ESP2
MOD.: Slot1

LAMPALLARME SUONERIA BUZZER LAMPALARM Q2.8	LAMPALLARME VERDE GREEN LAMPALARM Q2.9	LAMPALLARME GIALLO YELLOW LAMPALARM Q2.10	LAMPALLARME ROSSO RED LAMPALARM Q2.11	LAMPALLARME BLU BLUE LAMPALARM Q2.12	EV GENERALE GENERAL EV Q2.13	Q2.14	EV SELEZIONE SELECTION EV Q2.15	DC COM COM
OUT8	OUT9	OUT10	OUT11	OUT12	OUT13	OUT14	OUT15	COM

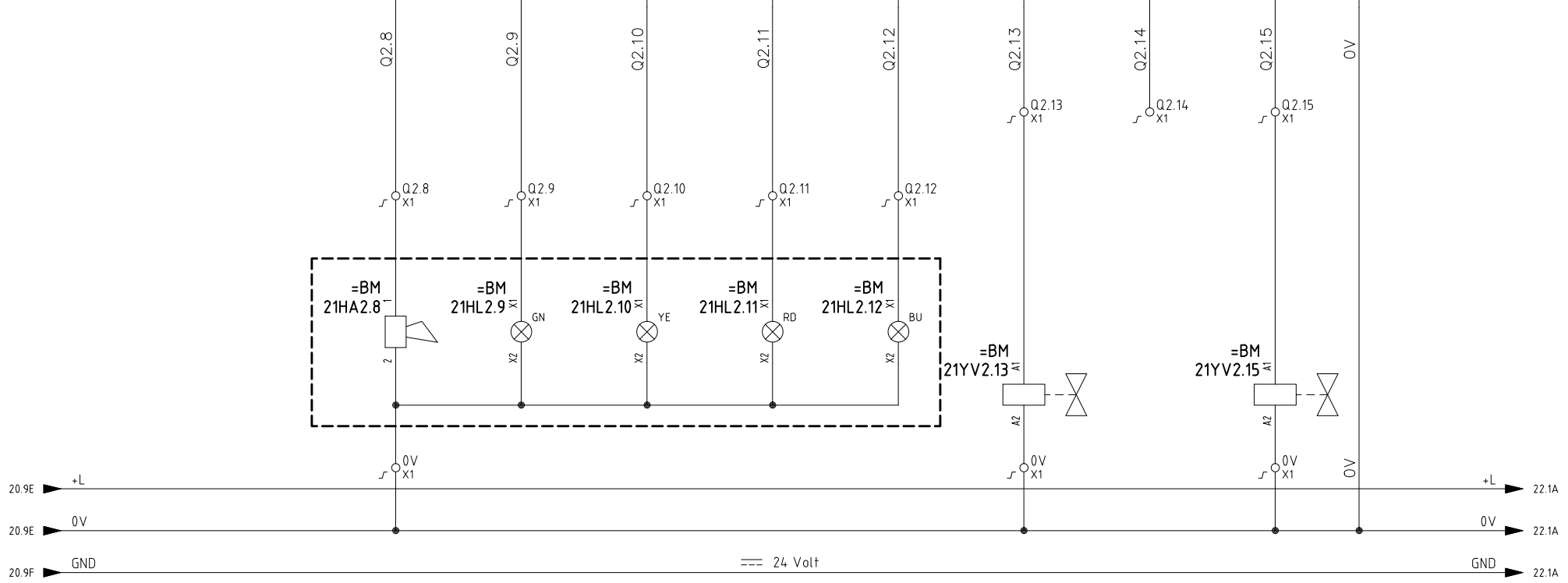

G	DISEGNATORE DESIGNER	FD	IMPIANTO PLANT	SCHEMA ELETTRICO GESTIONE IMPIANTO ROTARY CAPS WIRING DIAGRAM PLANT GESTION ROTARY CAPS				CAD	SPAC	
	NOME FILE FILE NAME	EKI_01388	DATA REVISIONE REVISION DATE	REV. n° REV. nr°	COMMESSA ORDER	DATA DATE	DESCRIZIONE PAGINA PAGE DESCRIPTION	PAG.	DI OF	
	SCHEMA N° DIAGRAM NR.	EKI_01388	02/07/13	1	37016	11/01/2012	USCITE OUTPUT	21	38	

THIS DRAWING SHALL NOT BE REPRODUCED OR IN ANY WAY UTILIZED WITHOUT WRITTEN CONSENT. ANY INFRINGEMENT WILL BE LEGALLY PURSUED.

A

B

C

D

E

F

G

1

2

3

4

5

6

7

8

9

A

B

C

D

E

F

G

<i>DISEGNATORE DESIGNER</i>	FD	<i>IMPIANTO PLANT</i>	SCHEMA ELETTRICO GESTIONE IMPIANTO ROTARY CAPS WIRING DIAGRAM PLANT GESTION ROTARY CAPS				<i>CAD</i>	SPAC	 bonino [®]
<i>NOME FILE FILE NAME</i>	EKI_01388	<i>DATA REVISIONE REVISION DATE</i>	<i>REV. n° REV. nr°</i>	<i>COMMESSA ORDER</i>	<i>DATA DATE</i>	<i>DESCRIZIONE PAGINA PAGE DESCRIPTION</i>	<i>PAG.</i>	<i>DI OF</i>	
<i>SCHEMA N° DIAGRAM NR.</i>	EKI_01388	02/07/13	1	37016	11/01/2012		21A	38	

1

2

3

4

5

6

7

8

9

THIS DRAWING SHALL NOT BE REPRODUCED OR IN ANY WAY UTILIZED WITHOUT WRITTEN CONSENT. ANY INFRINGEMENT WILL BE LEGALLY PURSUED.

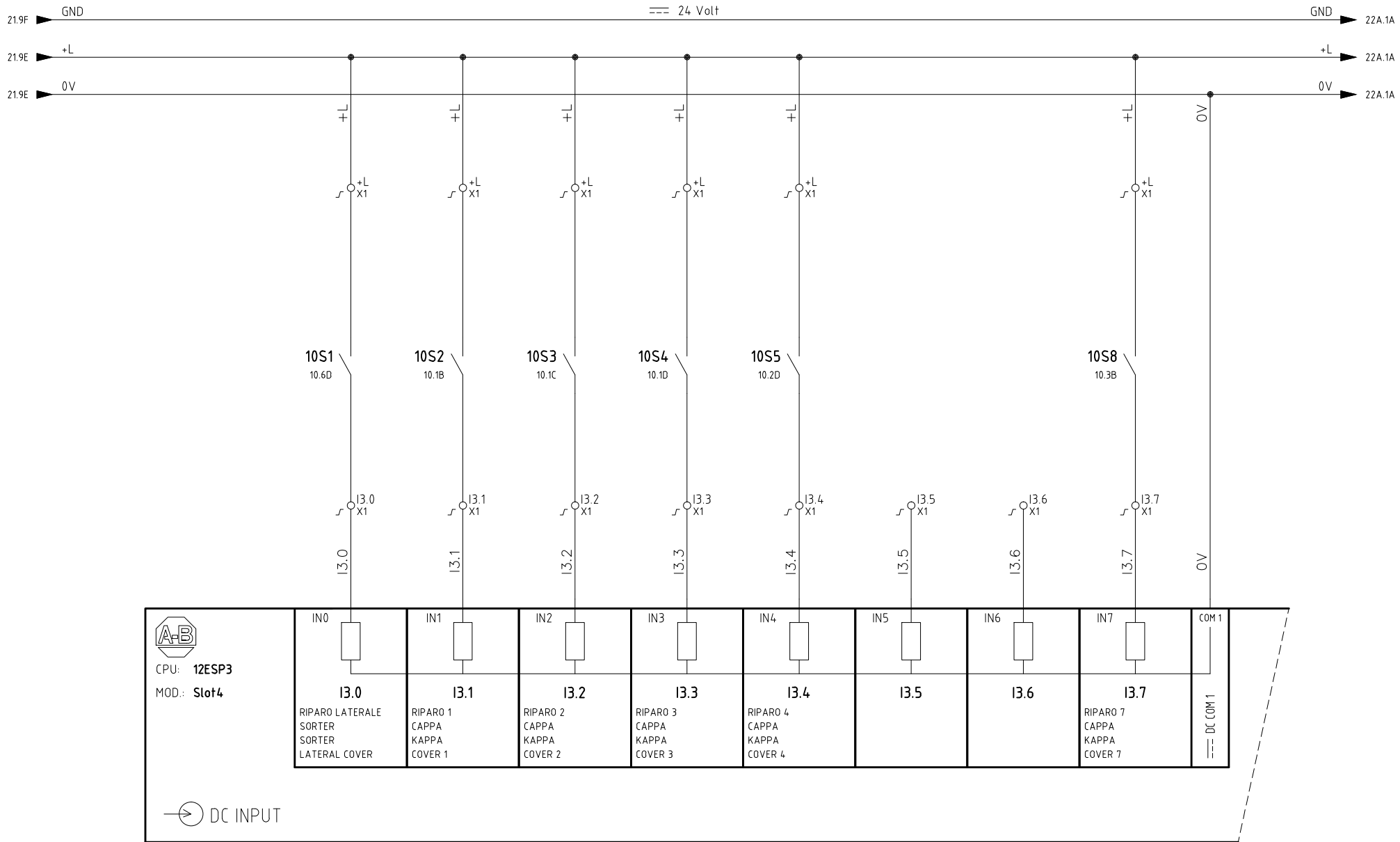

<i>DISEGNATORE DESIGNER</i>	FD	<i>IMPIANTO PLANT</i>	SCHEMA ELETTRICO GESTIONE IMPIANTO ROTARY CAPS WIRING DIAGRAM PLANT GESTION ROTARY CAPS				CAD	SPAC
<i>NOME FILE FILE NAME</i>	EKI_01388	<i>DATA REVISIONE REVISION DATE</i>	<i>REV. n° REV. nr°</i>	<i>COMMESSA ORDER</i>	<i>DATA DATE</i>	<i>DESCRIZIONE PAGINA PAGE DESCRIPTION</i>	PAG.	DI OF
<i>SCHEMA N° DIAGRAM NR.</i>	EKI_01388	02/07/13	1	37016	11/01/2012	INGRESSI INPUT	22	38



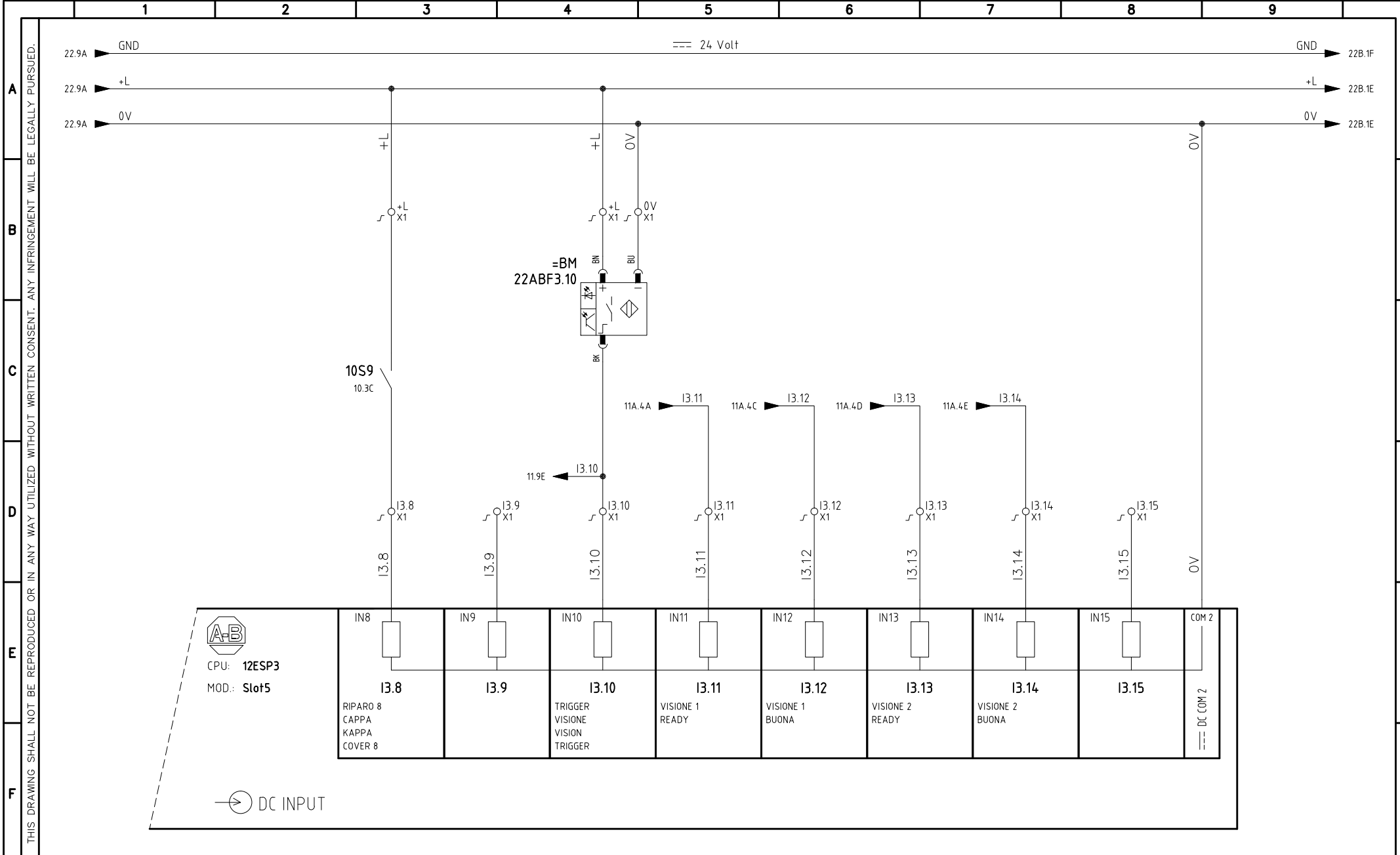

G	DISEGNATORE DESIGNER	FD	IMPIANTO PLANT	SCHEMA ELETTRICO GESTIONE IMPIANTO ROTARY CAPS WIRING DIAGRAM PLANT GESTION ROTARY CAPS				CAD	SPAC	
	NOME FILE FILE NAME	EKI_01388	DATA REVISIONE REVISION DATE	REV. n° REV. nr°	COMMESSA ORDER	DATA DATE	DESCRIZIONE PAGINA PAGE DESCRIPTION	PAG.	DI OF	
	SCHEMA N° DIAGRAM NR.	EKI_01388	02/07/13	1	37016	11/01/2012	INGRESSI INPUT	22A	38	

THIS DRAWING SHALL NOT BE REPRODUCED OR IN ANY WAY UTILIZED WITHOUT WRITTEN CONSENT. ANY INFRINGEMENT WILL BE LEGALLY PURSUED.

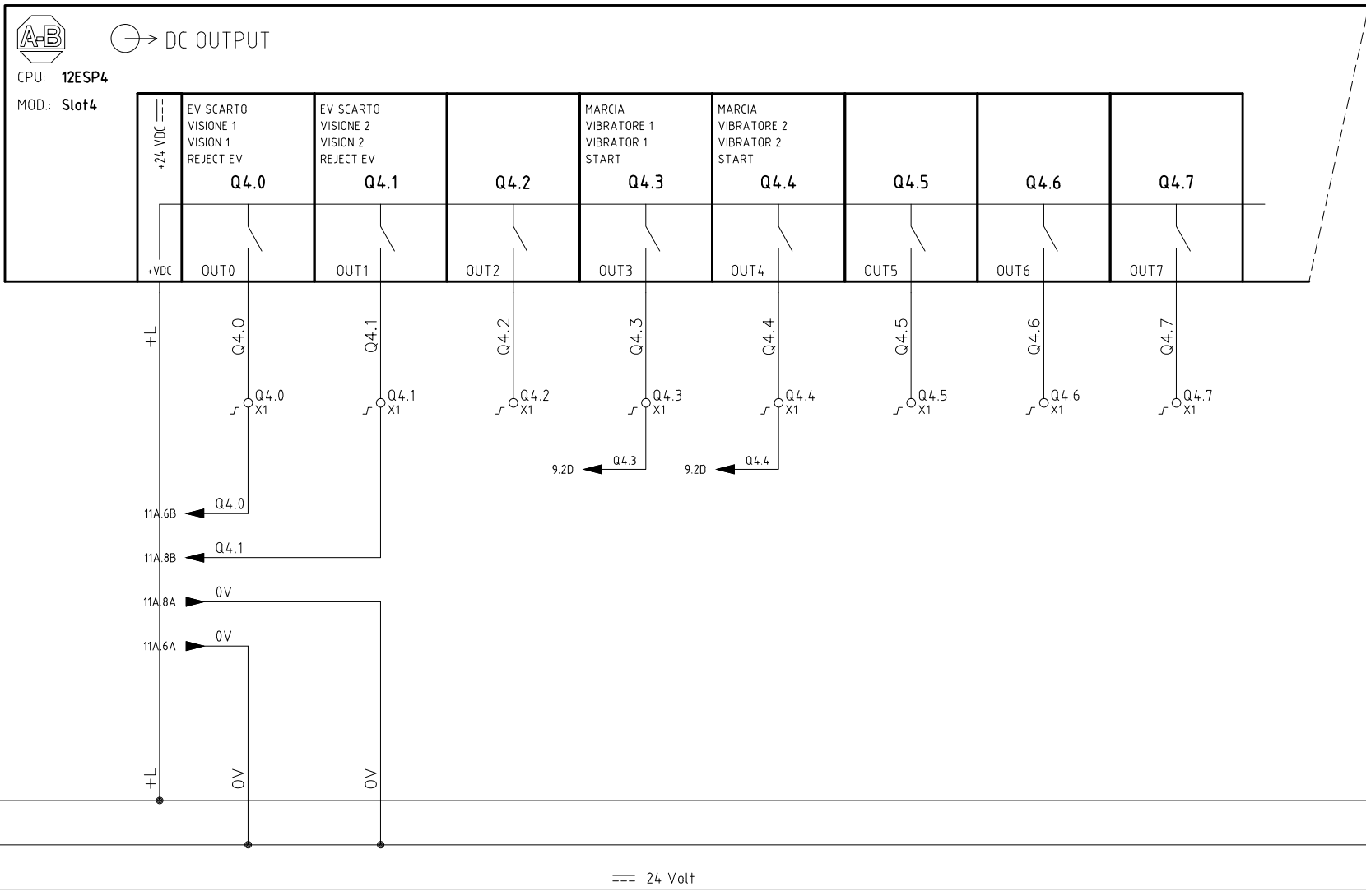

DISEGNATORE DESIGNER	FD	IMPIANTO PLANT	SCHEMA ELETTRICO GESTIONE IMPIANTO ROTARY CAPS WIRING DIAGRAM PLANT GESTION ROTARY CAPS				CAD	SPAC
NOME FILE FILE NAME	EKI_01388	DATA REVISIONE REVISION DATE	REV. n° REV. nr°	COMMESSA ORDER	DATA DATE	DESCRIZIONE PAGINA PAGE DESCRIPTION	PAG.	DI OF
SCHEMA N° DIAGRAM NR.	EKI_01388	02/07/13	1	37016	11/01/2012	USCITE OUTPUT	22B	38



THIS DRAWING SHALL NOT BE REPRODUCED OR IN ANY WAY UTILIZED WITHOUT WRITTEN CONSENT. ANY INFRINGEMENT WILL BE LEGALLY PURSUED.

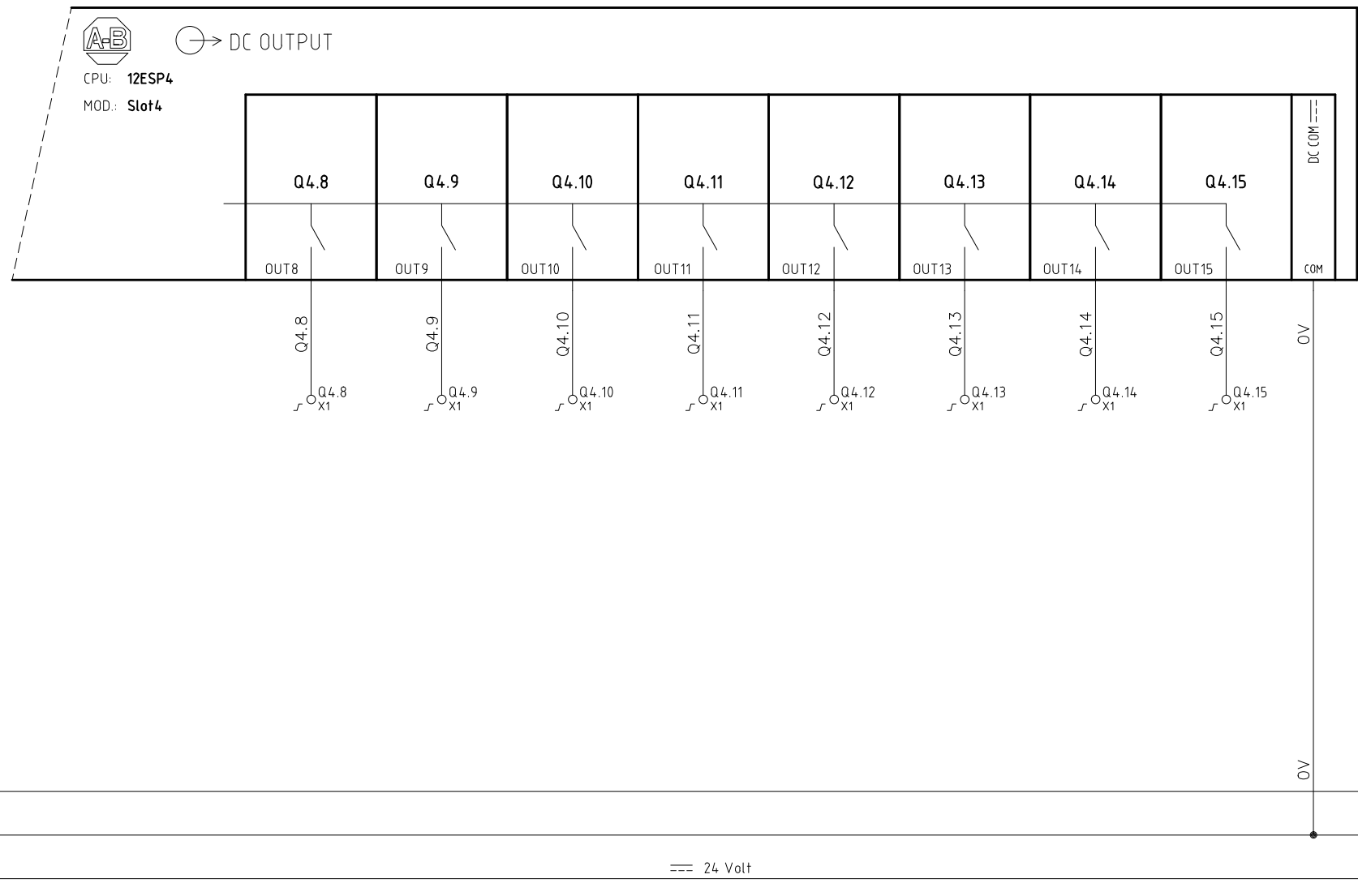

DISEGNATORE DESIGNER	FD	IMPIANTO PLANT	SCHEMA ELETTRICO GESTIONE IMPIANTO ROTARY CAPS WIRING DIAGRAM PLANT GESTION ROTARY CAPS				CAD	SPAC
NOME FILE FILE NAME	EKI_01388	DATA REVISIONE REVISION DATE	REV. n° REV. nr°	COMMESSA ORDER	DATA DATE	DESCRIZIONE PAGINA PAGE DESCRIPTION	PAG.	DI OF
SCHEMA N° DIAGRAM NR.	EKI_01388	02/07/13	1	37016	11/01/2012	USCITE OUTPUT	22C	38



THIS DRAWING SHALL NOT BE REPRODUCED OR IN ANY WAY UTILIZED WITHOUT WRITTEN CONSENT. ANY INFRINGEMENT WILL BE LEGALLY PURSUED.

A
B
C
D
E
F

A
B
C
D
E
F

1 2 3 4 5 6 7 8 9

G	<i>DISEGNATORE DESIGNER</i>	FD	<i>IMPIANTO PLANT</i>	SCHEMA ELETTRICO GESTIONE IMPIANTO ROTARY CAPS WIRING DIAGRAM PLANT GESTION ROTARY CAPS				<i>CAD</i>	SPAC	
	<i>NOME FILE FILE NAME</i>	EKI_01388	<i>DATA REVISIONE REVISION DATE</i>	<i>REV. n° REV. nr°</i>	<i>COMMESSA ORDER</i>	<i>DATA DATE</i>	<i>DESCRIZIONE PAGINA PAGE DESCRIPTION</i>	<i>PAG.</i>	<i>DI OF</i>	
	<i>SCHEMA N° DIAGRAM NR.</i>	EKI_01388	02/07/13	1	37016	11/01/2012		22D	38	

1 2 3 4 5 6 7 8 9

THIS DRAWING SHALL NOT BE REPRODUCED OR IN ANY WAY UTILIZED WITHOUT WRITTEN CONSENT. ANY INFRINGEMENT WILL BE LEGALLY PURSUED.

CUSTOMER

INSERTION
AUXILIARY

EXTERNAL
ENEBLE

EMERGENCY

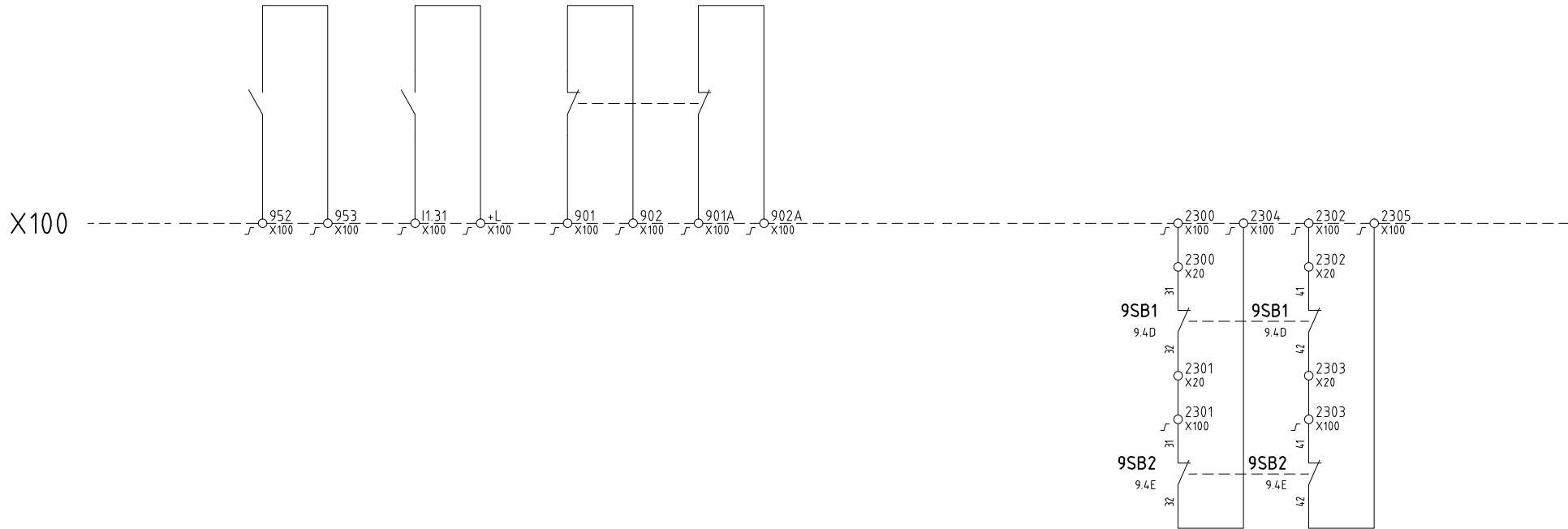

SUPPLIER

EMERGENCY

G	DISEGNATORE DESIGNER	FD	IMPIANTO PLANT	SCHEMA ELETTRICO GESTIONE IMPIANTO ROTARY CAPS WIRING DIAGRAM PLANT GESTION ROTARY CAPS				CAD	SPAC	 bonino ®
	NOME FILE FILE NAME	EKI_01388	DATA REVISIONE REVISION DATE	REV. n° REV. nr°	COMMESSA ORDER	DATA DATE	DESCRIZIONE PAGINA PAGE DESCRIPTION	PAG.	DI OF	
	SCHEMA N° DIAGRAM NR.	EKI_01388	02/07/13	1	37016	11/01/2012	INTERFACCIA INTERFACE	23	38	

THIS DRAWING SHALL NOT BE REPRODUCED OR IN ANY WAY UTILIZED WITHOUT WRITTEN CONSENT. ANY INFRINGEMENT WILL BE LEGALLY PURSUED.

=QG - X1P POWER BOARD TERMINAL

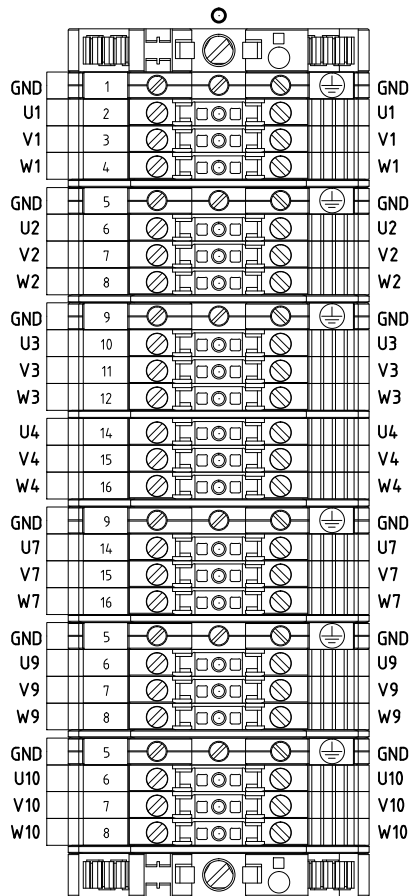

=QG - X1C CONTROL BOARD TERMINAL

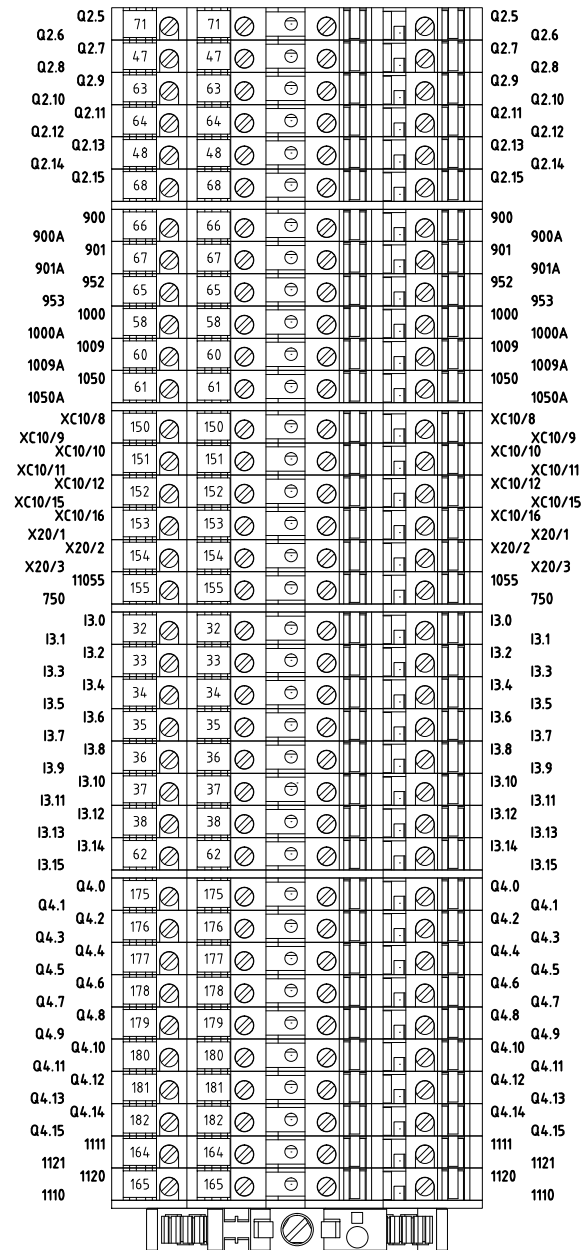
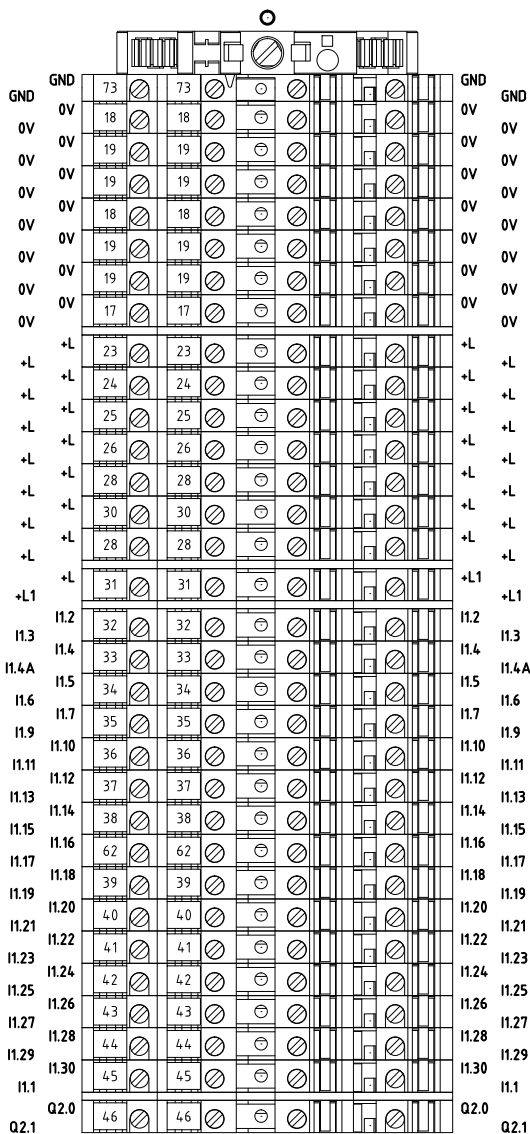

DISEGNATORE DESIGNER	FD	IMPIANTO PLANT	SCHEMA ELETTRICO GESTIONE IMPIANTO ROTARY CAPS WIRING DIAGRAM PLANT GESTION ROTARY CAPS				CAD	SPAC
NOME FILE FILE NAME	EKI_01388	DATA REVISIONE REVISION DATE	REV. n° REV. nr°	COMMESSA ORDER	DATA DATE	DESCRIZIONE PAGINA PAGE DESCRIPTION	PAG. DI OF	
SCHEMA N° DIAGRAM NR.	EKI_01388	02/07/13	1	37016	11/01/2012	MORSETTIERE TERMINALS	24 38	



A

B

C

D

E

F

G

A

B

C

D

E

F

G

THIS DRAWING SHALL NOT BE REPRODUCED OR IN ANY WAY UTILIZED WITHOUT WRITTEN CONSENT. ANY INFRINGEMENT WILL BE LEGALLY PURSUED.

=QG - X100
INTERFACE TERMINAL

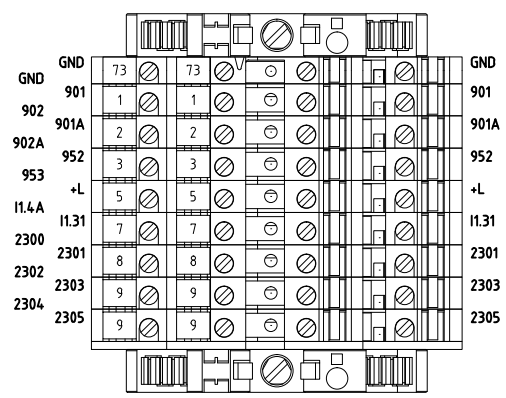

=BM - X10P
POWER ELEVATOR TERMINAL

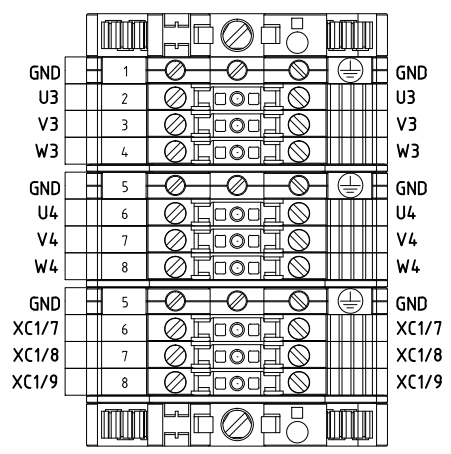

=BM - X10C
COMMAND ELEVATOR TERMINAL

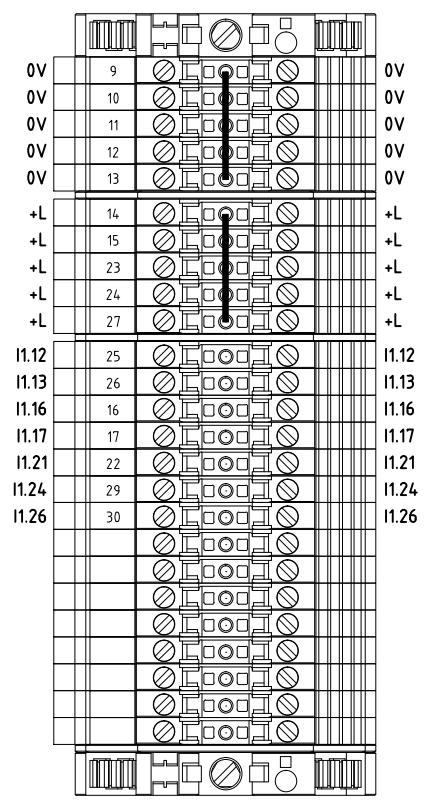

=P1 - X20
PUSHBUTTON BOX TERMINAL

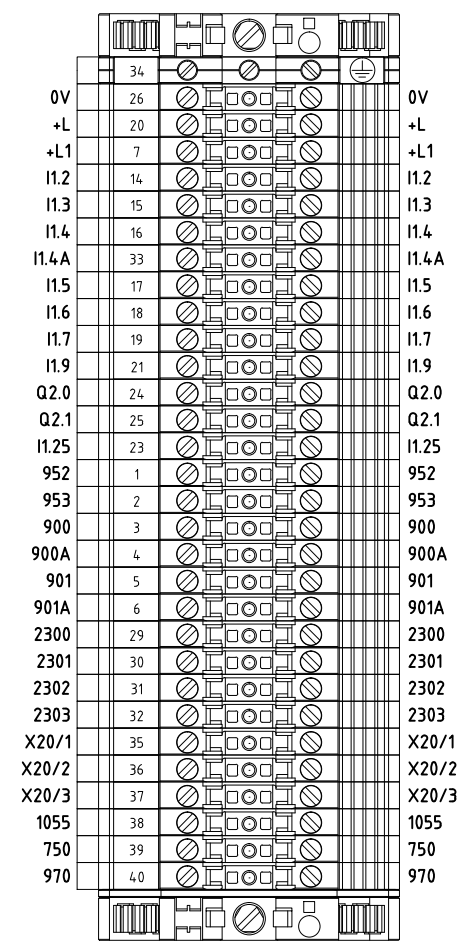

=BM - X23
MORSETTIERA VIBRATORI

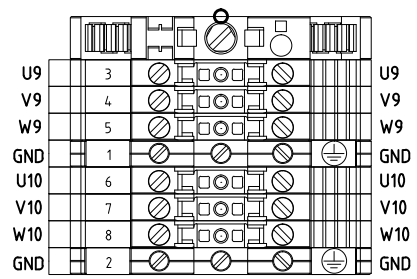

=BM - XC1 **=BM - XC10**
POWER ELEVATOR COMMAND ELEVATOR

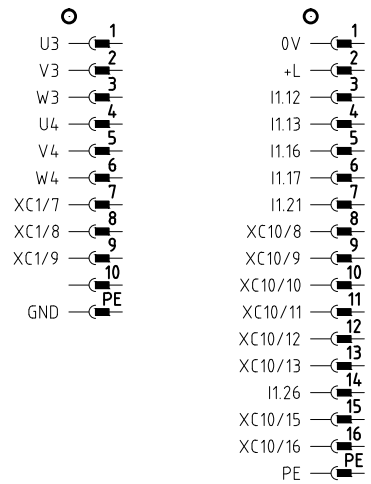

=P1 - XC12
JOG

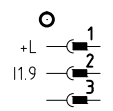

G	DISEGNATORE DESIGNER	FD	IMPIANTO PLANT	SCHEMA ELETTRICO GESTIONE IMPIANTO ROTARY CAPS WIRING DIAGRAM PLANT GESTION ROTARY CAPS			CAD	SPAC	
	NOME FILE FILE NAME	EKI_01388	DATA REVISIONE REVISION DATE	REV. n° REV. nr°	COMMESSA ORDER	DATA DATE	DESCRIZIONE PAGINA PAGE DESCRIPTION	PAG. DI OF	
	SCHEMA N° DIAGRAM NR.	EKI_01388	02/07/13	1	37016	11/01/2012	MORSETTIERE TERMINALS	25 38	

CAVI ESTERNI \ EXTERNAL CABLES

THIS DRAWING SHALL NOT BE REPRODUCED OR IN ANY WAY UTILIZED WITHOUT WRITTEN CONSENT. ANY INFRINGEMENT WILL BE LEGALLY PURSUED.

QUADRO \ BOARD				CAVO					DESTINAZIONE \ LOCATION				
QUADRO BOARD	FOGLIO SHEET	NR. MORSETTO TERMINAL NO.	NR. FILO CONDUCTOR NO.	ID SUL CAVO ID IN CABLE	CAVO CABLE	LUNGHEZZA LENGHT (mt)	DISTURBO NOISE LEVEL	ID SUL CAVO ID IN CABLE	NR. FILO CONDUCTOR NO.	NR. MORSETTO TERMINAL NO.	FOGLIO SHEET	QUADRO BOARD	
=QG X1	20/2D	0V	0V	1	X20A REI 1119 025 25G0.5 PUSHBUTTON BOX			1	0V	0V	20/2D	=P1 X20	
=QG X1	16/3B	+L	+L	2				2	+L	+L	+L	16/3B	=P1 X20
=QG X1	9/8B	+L1	+L1	3				3	+L1	+L1	+L1	9/8B	=P1 X20
=QG X1	9/4A	952	952	4				4	952	952	952	9/4A	=P1 X20
=QG X1	9/4B	953	953	5				5	953	953	953	9/4A	=P1 X20
=QG X1	15/4C	11.2	11.2	6				6	11.2	11.2	11.2	15/4C	=P1 X20
=QG X1	15/4C	11.3	11.3	7				7	11.3	11.3	11.3	15/4C	=P1 X20
=QG X1	15/5C	11.4	11.4	8				8	11.4	11.4	11.4	15/5C	=P1 X20
=QG X1	15/5B	11.4A	11.4A	9				9	11.4A	11.4A	11.4A	15/5B	=P1 X20
=QG X1	15/6C	11.5	11.5	10				10	11.5	11.5	11.5	15/6C	=P1 X20
=QG X1	15/7C	11.6	11.6	11				11	11.6	11.6	11.6	15/7C	=P1 X20
=QG X1	15/7C	11.7	11.7	12				12	11.7	11.7	11.7	15/7C	=P1 X20
=QG X1	16/3C	11.9	11.9	13				13	11.9	11.9	11.9	16/3C	=P1 X20
=QG X1	20/2D	Q2.0	Q2.0	14				14	Q2.0	Q2.0	Q2.0	20/2D	=P1 X20
=QG X1	20/3D	Q2.1	Q2.1	15			15	Q2.1	Q2.1	Q2.1	20/3D	=P1 X20	
=QG X1	18/3D	11.25	11.25	16			16	11.25	11.25	11.25	18/3D	=P1 X20	
=QG X1	9/4C	900A	900A	17			17	900A	900A	900A	9/4C	=P1 X20	
=QG X100	9/4D	901A	901A	18			18	901A	901A	901A	9/4C	=P1 X20	
=QG X1	9/3C	900	900	19			19	900	900	900	9/3C	=P1 X20	
=QG X100	9/3D	901	901	20			20	901	901	901	9/3C	=P1 X20	
=QG X100	23/7C	2300	2300	21			21	2300	2300	2300	23/7C	=P1 X20	
=QG X100	23/7C	2301	2301	22			22	2301	2301	2301	23/7C	=P1 X20	
=QG X100	23/7C	2302	2302	23			23	2302	2302	2302	23/7C	=P1 X20	
=QG X100	23/7C	2303	2303	24			24	2303	2303	2303	23/7C	=P1 X20	
=QG X100	23/8C	2303	2303	24			24	2303	2303	2303	23/8C	=P1 X20	
		GND	GND	GNYE			GNYE	GND	GND	GND			
=QG X1	10A/4E	X20/1	X20/1	1	X20 REI 1119 010 10G0.5 PUSHBUTTON BOX			1	X20/1	X20/1	10A/4D	=P1 X20	
=QG X1	10A/5E	X20/2	X20/2	2				2	X20/2	X20/2	X20/2	10A/5D	=P1 X20
=QG X1	10A/5E	X20/3	X20/3	3				3	X20/3	X20/3	X20/3	10A/5D	=P1 X20
=QG X1	10A/5E	1055	1055	4				4	1055	1055	1055	10A/5D	=P1 X20
=QG X1	10A/6E	750	750	5				5	750	750	750	10A/6D	=P1 X20
=QG X1	10A/6E	970	970	6				6	970	970	970	10A/6D	=P1 X20
		GND	GND	GNYE			GNYE	GND	GND	GND			

DISEGNATORE DESIGNER	FD	IMPIANTO PLANT	SCHEMA ELETTRICO GESTIONE IMPIANTO ROTARY CAPS WIRING DIAGRAM PLANT GESTION ROTARY CAPS				CAD	SPAC	
NOME FILE FILE NAME	EKI_01388	DATA REVISIONE REVISION DATE	REV. n° REV. nr°	COMMESSA ORDER	DATA DATE	DESCRIZIONE PAGINA PAGE DESCRIPTION	PAG.	DI OF	
SCHEMA N° DIAGRAM NR.	EKI_01388	02/07/13	1	37016	11/01/2012	LISTA CAVI CABLE LIST	26	38	



CAVI ESTERNI \ EXTERNAL CABLES

QUADRO \ BOARD									DESTINAZIONE \ LOCATION			
QUADRO BOARD	FOGLIO SHEET	NR. MORSETTO TERMINAL NO.	NR. FILO CONDUCTOR NO.	ID SUL CAVO ID IN CABLE	CAVO CABLE	LUNGHEZZA LENGHT (mt)	DISTURBO NOISE LEVEL	ID SUL CAVO ID IN CABLE	NR. FILO CONDUCTOR NO.	NR. MORSETTO TERMINAL NO.	FOGLIO SHEET	QUADRO BOARD
=QG X1	21/2D	0V ○	0V	1	21HL REI 1119 007 7G0.5 LAMPALARM			1	0V	21HL	21/2D	=BM 21HA2.8 =BM 21HL2.9 =BM 21HL2.10 =BM 21HL2.11 =BM 21HL2.12
=QG X1	21/2C	Q2.8 ○	Q2.8	2				2	Q2.8	21HL	21/2D	
=QG X1	21/3C	Q2.9 ○	Q2.9	3				3	Q2.9	21HL	21/3D	
=QG X1	21/4C	Q2.10 ○	Q2.10	4				4	Q2.10	21HL	21/4D	
=QG X1	21/4C	Q2.11 ○	Q2.11	5				5	Q2.11	21HL	21/4D	
=QG X1	21/4C	Q2.12 ○	Q2.12	6				6	Q2.12	21HL	21/5D	
=QG X1	21/5C	Q2.12 ○	Q2.12	6				GNYE		21HL	21/5D	
=QG X1	4/4D	U9 ○	U9	1	W23 REI 1119 007 7G1.5 VIBRATORS			1	U9	U9	4/4D	=BM X23 =BM X23 =BM X23 =BM X23 =BM X23 =BM X23 =BM X23
=QG X1	4/4D	V9 ○	V9	2				2	V9	U9	4/4D	
=QG X1	4/4D	W9 ○	W9	3				3	W9	V9	4/4D	
=QG X1	4/6D	U10 ○	U10	4				4	U10	W9	4/4D	
=QG X1	4/6D	V10 ○	V10	5				5	V10	U10	4/6D	
=QG X1	4/6D	W10 ○	W10	6				6	W10	V10	4/6D	
=QG X1	4/4D	PE ○	PE	GNYE				GNYE		W10	4/6D	
							PE	4/4D				

DISEGNATORE DESIGNER	FD	IMPIANTO PLANT	SCHEMA ELETTRICO GESTIONE IMPIANTO ROTARY CAPS WIRING DIAGRAM PLANT GESTION ROTARY CAPS				CAD	SPAC	
NOME FILE FILE NAME	EKI_01388	DATA REVISIONE REVISION DATE	REV. n° REV. nr°	COMMESSA ORDER	DATA DATE	DESCRIZIONE PAGINA PAGE DESCRIPTION	PAG.	DI OF	
SCHEMA N° DIAGRAM NR.	EKI_01388	02/07/13	1	37016	11/01/2012	LISTA CAVI CABLE LIST	26A	38	

THIS DRAWING SHALL NOT BE REPRODUCED OR IN ANY WAY UTILIZED WITHOUT WRITTEN CONSENT. ANY INFRINGEMENT WILL BE LEGALLY PURSUED.

THIS DRAWING SHALL NOT BE REPRODUCED OR IN ANY WAY UTILIZED WITHOUT WRITTEN CONSENT. ANY INFRINGEMENT WILL BE LEGALLY PURSUED.

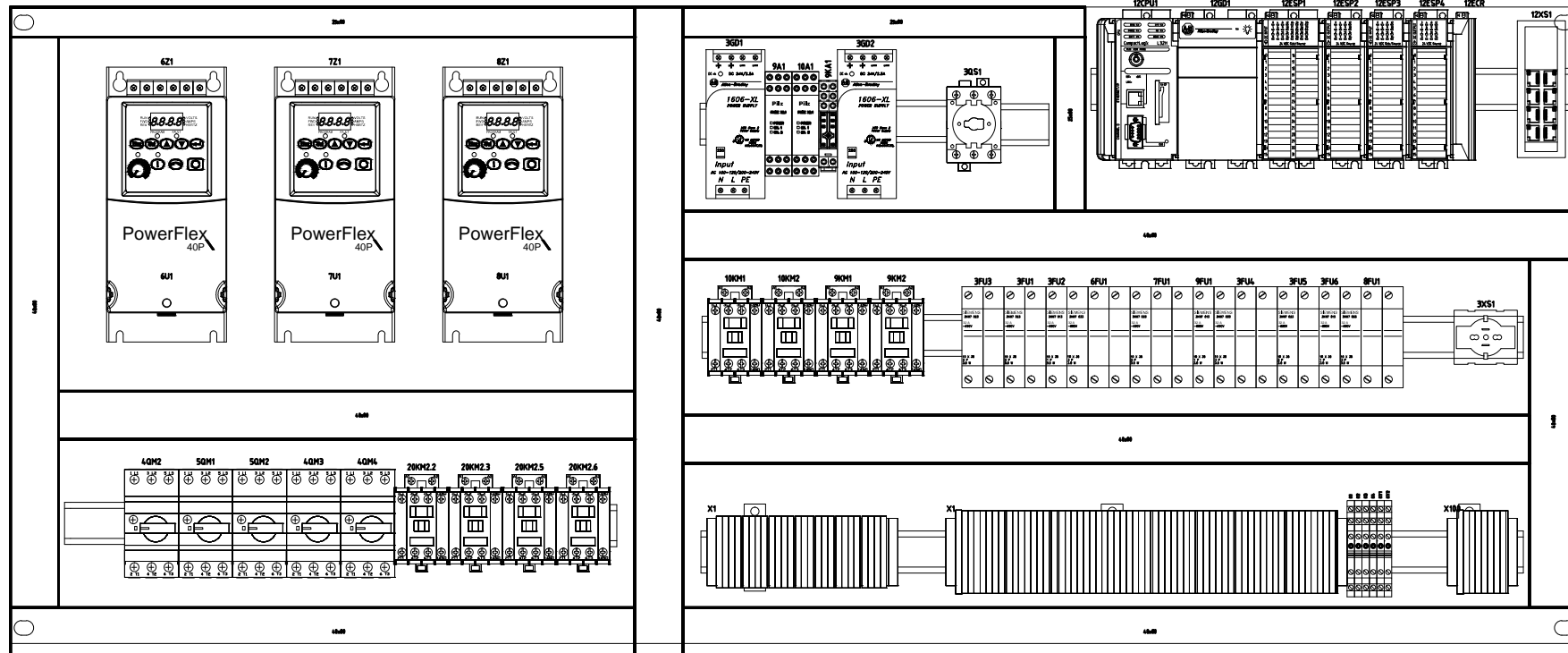

G	DISEGNATORE DESIGNER	FD	IMPIANTO PLANT	SCHEMA ELETTRICO GESTIONE IMPIANTO ROTARY CAPS WIRING DIAGRAM PLANT GESTION ROTARY CAPS				CAD	SPAC	 bonino ®
	NOME FILE FILE NAME	EKI_01388	DATA REVISIONE REVISION DATE	REV. n° REV. nr°	COMMESSA ORDER	DATA DATE	DESCRIZIONE PAGINA PAGE DESCRIPTION	PAG.	DI OF	
	SCHEMA N° DIAGRAM NR.	EKI_01388	02/07/13	1	37016	11/01/2012	LAY-OUT LAY-OUT	27	38	

THIS DRAWING SHALL NOT BE REPRODUCED OR IN ANY WAY UTILIZED WITHOUT WRITTEN CONSENT. ANY INFRINGEMENT WILL BE LEGALLY PURSUED.

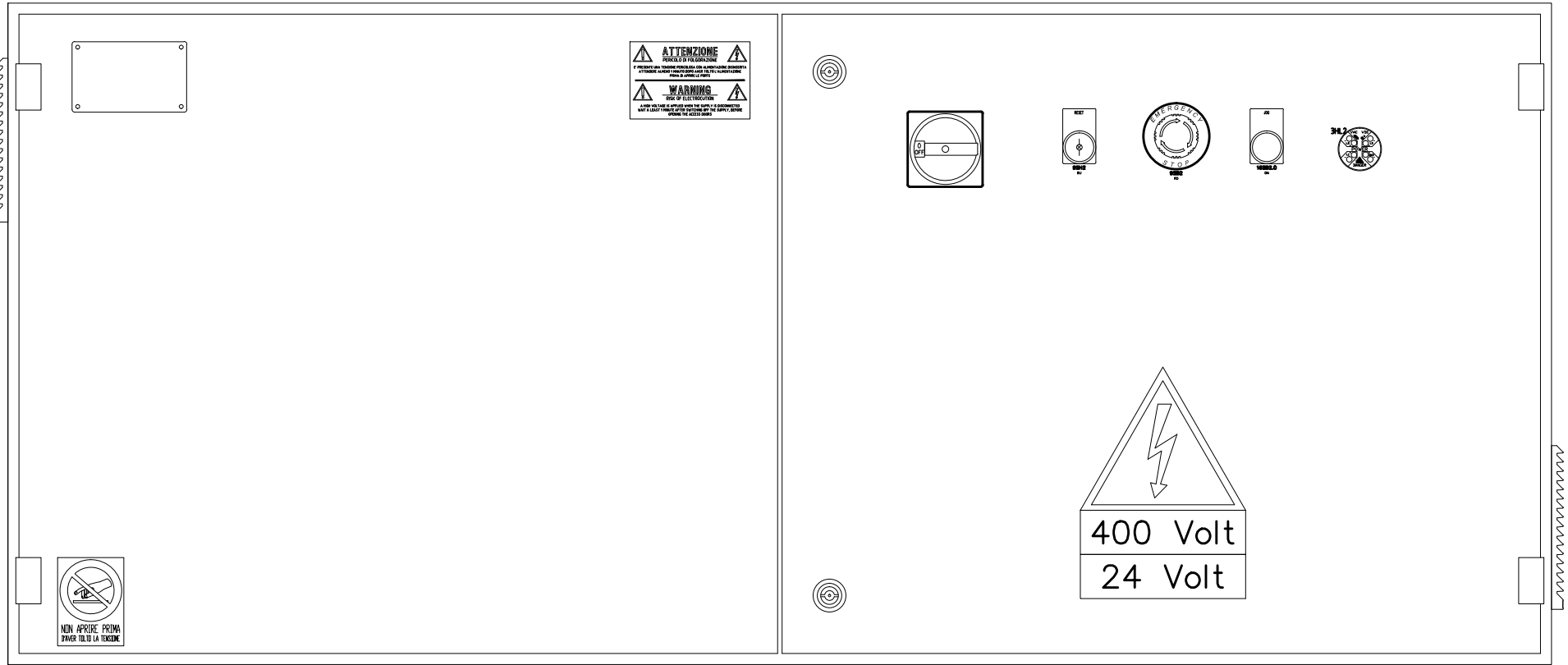



ATTENZIONE
 PERICOLO DI FULMINEGGIAZIONE
 È PROIBITO MANIPOLARE QUALSIASI CAVO O COMPONENTE QUALSIASI
 SIA IL DISPOSITIVO SOTTO TENSIONE. PER INFORMAZIONI
 LEGGERE IL MANUALE D'USO.
WARNING
 RISK OF ELECTROCUTION
 IT IS PROHIBITED TO TOUCH ANY PART OF THE EQUIPMENT
 WHILE IT IS UNDER POWER. FOR MORE INFORMATION
 READ THE USER MANUAL.

**NON APRIRE PRIMA
 PRIMA DI Togliere LA TENSIONE**

400 Volt
24 Volt

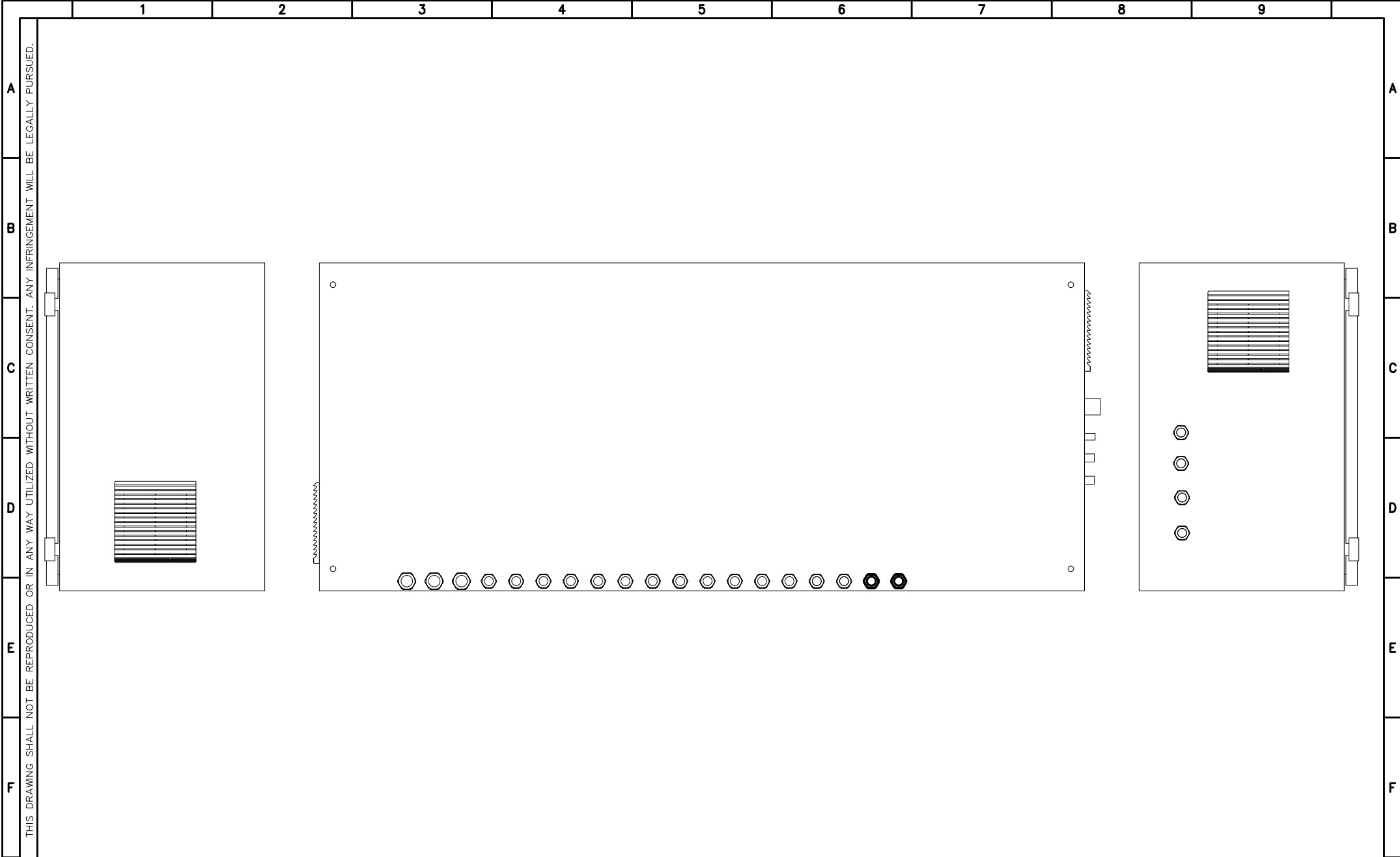
G	DISEGNATORE DESIGNER		IMPIANTO PLANT		SCHEMA ELETTRICO GESTIONE IMPIANTO ROTARY CAPS WIRING DIAGRAM PLANT GESTION ROTARY CAPS			CAD	SPAC		
	NOME FILE FILE NAME		DATA REVISIONE REVISION DATE		REV. n° REV. nr°	COMMESSA ORDER	DATA DATE	DESCRIZIONE PAGINA PAGE DESCRIPTION	PAG.		DI OF
	SCHEMA N° DIAGRAM NR.		02/07/13		1	37016	11/01/2012	LAY-OUT LAY-OUT	28		38



G	<i>DISEGNATORE</i> <i>DESIGNER</i>		FD		<i>IMPIANTO</i> <i>PLANT</i>		SCHEMA ELETTRICO GESTIONE IMPIANTO ROTARY CAPS WIRING DIAGRAM PLANT GESTION ROTARY CAPS				<i>CAD</i>		SPAC		
	<i>NOME FILE</i> <i>FILE NAME</i>		EKI_01388		<i>DATA REVISIONE</i> <i>REVISION DATE</i>		<i>REV. n°</i> <i>REV. nr°</i>	<i>COMMESSA</i> <i>ORDER</i>	<i>DATA</i> <i>DATE</i>	<i>DESCRIZIONE PAGINA</i> <i>PAGE DESCRIPTION</i>			<i>PAG.</i>	<i>DI</i> <i>OF</i>	
	<i>SCHEMA N°</i> <i>DIAGRAM NR.</i>		EKI_01388		02/07/13		1	37016	11/01/2012	LAY-OUT LAY-OUT			29	38	

THIS DRAWING SHALL NOT BE REPRODUCED OR IN ANY WAY UTILIZED WITHOUT WRITTEN CONSENT. ANY INFRINGEMENT WILL BE LEGALLY PURSUED.

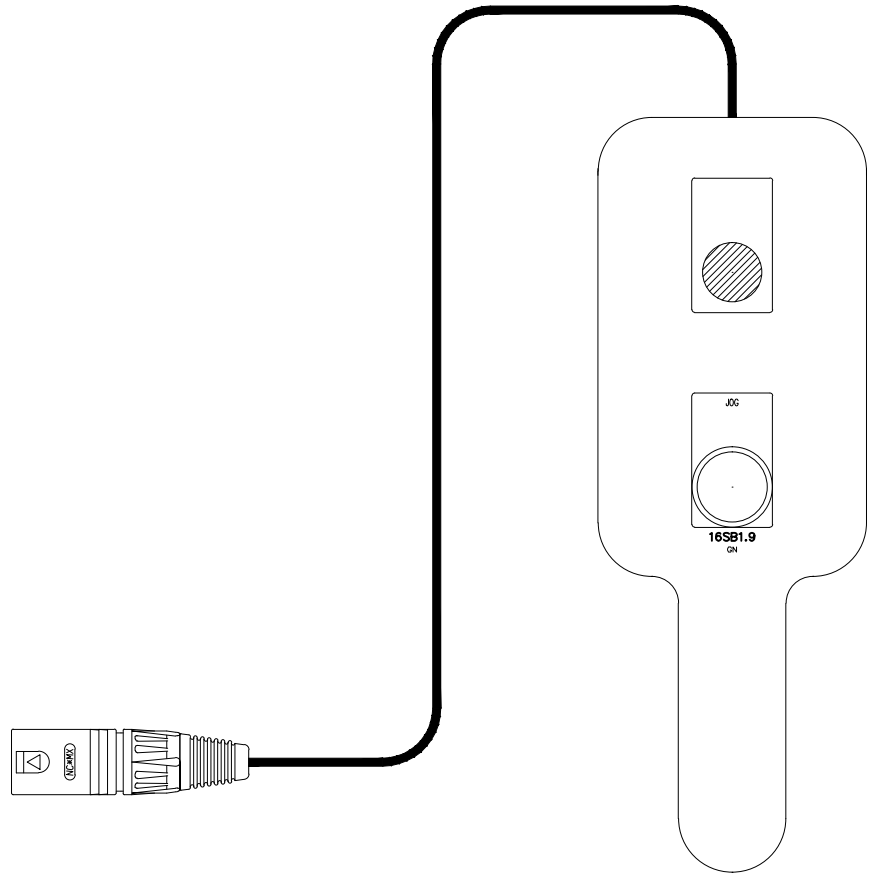
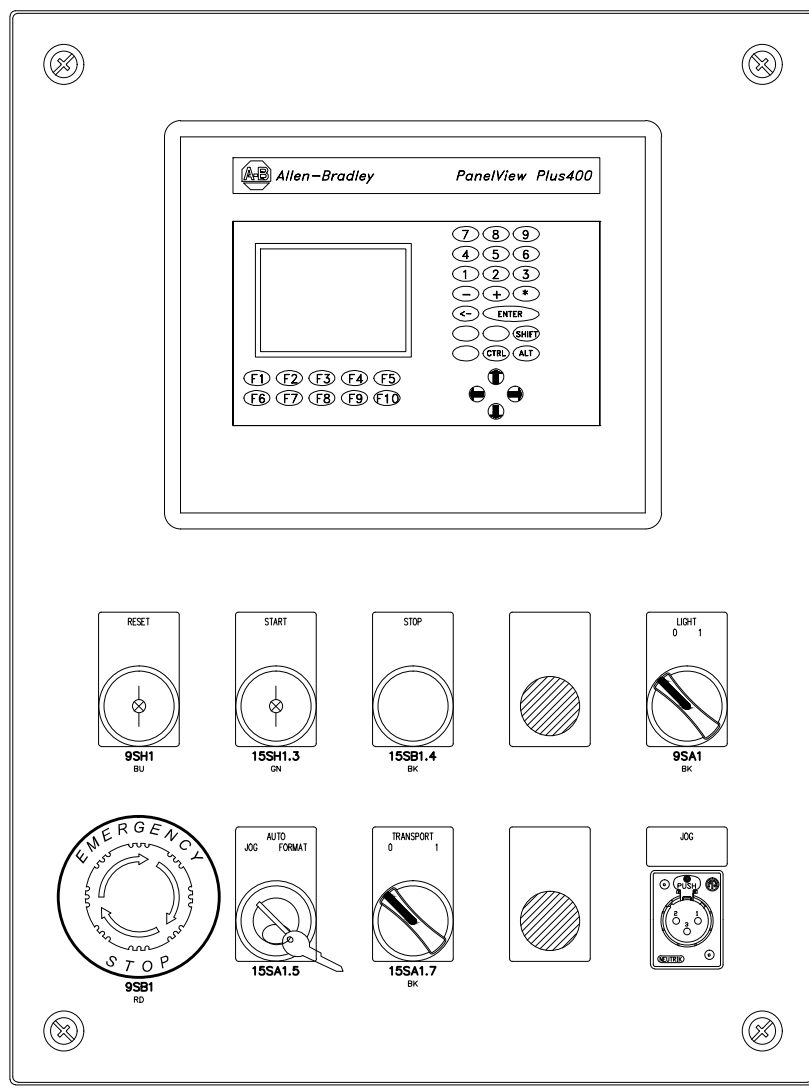

G	DISEGNATORE DESIGNER	FD	IMPIANTO PLANT	SCHEMA ELETTRICO GESTIONE IMPIANTO ROTARY CAPS WIRING DIAGRAM PLANT GESTION ROTARY CAPS			CAD	SPAC	
	NOME FILE FILE NAME	EKI_01388	DATA REVISIONE REVISION DATE	REV. n° REV. nr°	COMMESSA ORDER	DATA DATE	DESCRIZIONE PAGINA PAGE DESCRIPTION	PAG. DI OF	
	SCHEMA N° DIAGRAM NR.	EKI_01388	02/07/13	1	37016	11/01/2012	LAY-OUT LAY-OUT	30 38	

THIS DRAWING SHALL NOT BE REPRODUCED OR IN ANY WAY UTILIZED WITHOUT WRITTEN CONSENT. ANY INFRINGEMENT WILL BE LEGALLY PURSUED.

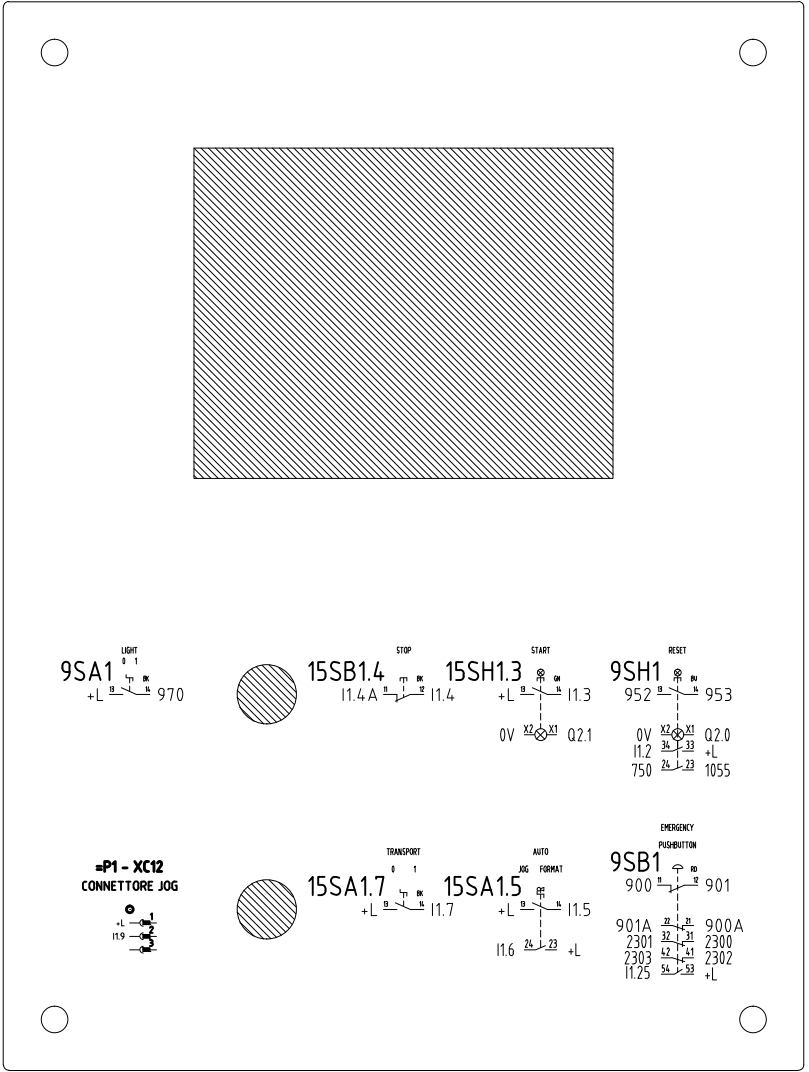
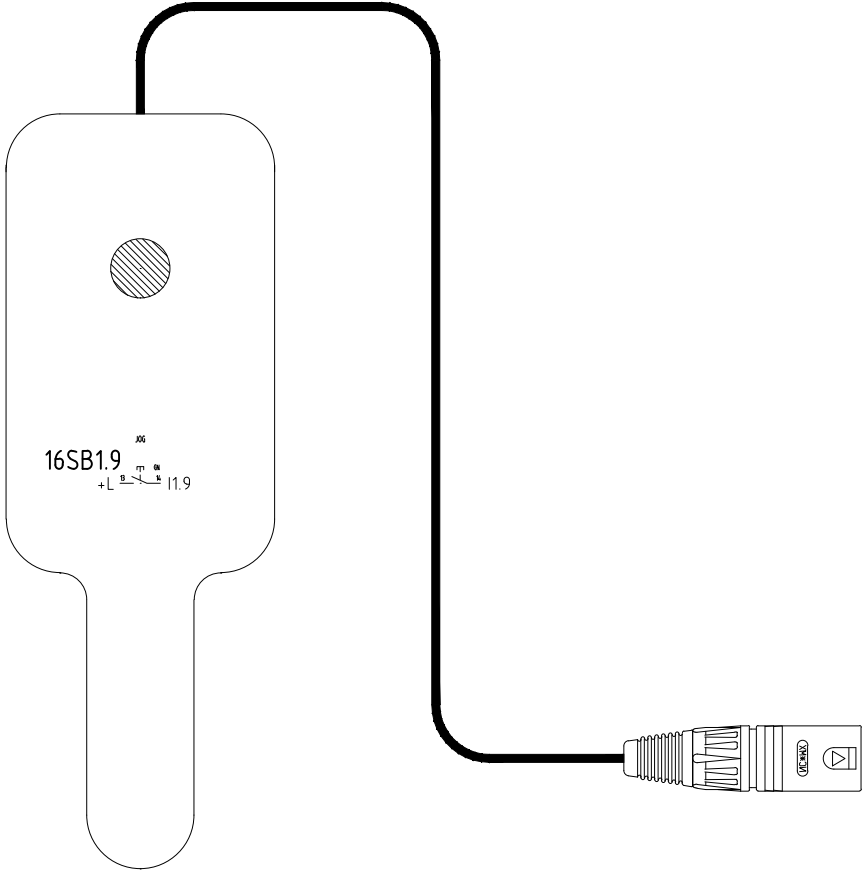

G	DISEGNATORE DESIGNER	FD	IMPIANTO PLANT	SCHEMA ELETTRICO GESTIONE IMPIANTO ROTARY CAPS WIRING DIAGRAM PLANT GESTION ROTARY CAPS				CAD	SPAC	
	NOME FILE FILE NAME	EKI_01388	DATA REVISIONE REVISION DATE	REV. n° REV. nr°	COMMESSA ORDER	DATA DATE	DESCRIZIONE PAGINA PAGE DESCRIPTION	PAG.	DI OF	
	SCHEMA N° DIAGRAM NR.	EKI_01388	02/07/13	1	37016	11/01/2012	LAY-OUT LAY-OUT	31	38	

THIS DRAWING SHALL NOT BE REPRODUCED OR IN ANY WAY UTILIZED WITHOUT WRITTEN CONSENT. ANY INFRINGEMENT WILL BE LEGALLY PURSUED.

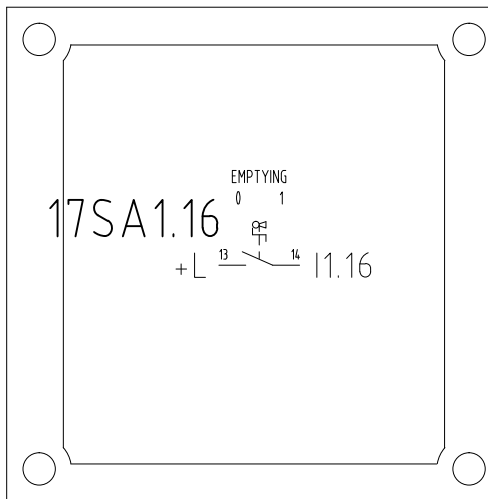
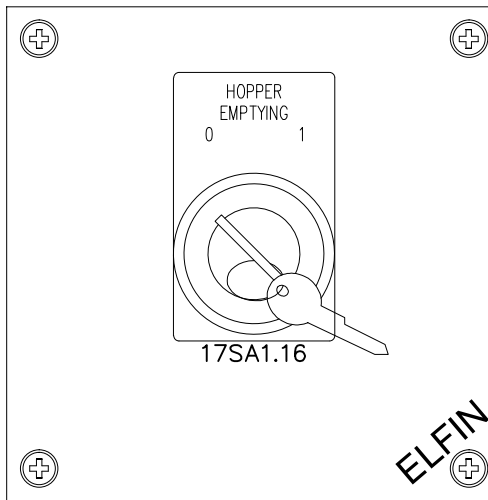

G	DISEGNATORE DESIGNER	FD	IMPIANTO PLANT	SCHEMA ELETTRICO GESTIONE IMPIANTO ROTARY CAPS WIRING DIAGRAM PLANT GESTION ROTARY CAPS			CAD	SPAC
	NOME FILE FILE NAME	EKI_01388	DATA REVISIONE REVISION DATE	REV. n° REV. nr°	COMMESSA ORDER	DATA DATE	DESCRIZIONE PAGINA PAGE DESCRIPTION	PAG. DI OF
	SCHEMA N° DIAGRAM NR.	EKI_01388	02/07/13	1	37016	11/01/2012	LAY-OUT LAY-OUT	31A 38



1		2		3		4		5		6		7		8		9		
A	THIS DRAWING SHALL NOT BE REPRODUCED OR IN ANY WAY UTILIZED WITHOUT WRITTEN CONSENT. ANY INFRINGEMENT WILL BE LEGALLY PURSUED.																	
	Nome/Item	Fg/Sh	Descrizione/Description										Costruttore/Marke		Tipo/Type		Q.ta/Q.ty	Quadro/Board
B	3FU1	3	BASE SEZ.X FUS.CILINDR.10x38 32A 2P 2UM FUSE CILIND.-gG ACR 10,3x38-10A s/seg.										Siemens	3NW7023	1	=QG		
	3FU2	3	BASE SEZ.X FUS.CILINDR.10x38 32A 1P 1UM FUSE CILIND.-gG ACR 10,3x38-4A s/segn.										Siemens	3NW7013	1	=QG		
	3FU3	3	BASE SEZ.X FUS.CILINDR.10x38 32A 2P 2UM FUSE CILIND.-gG ACR 10,3x38-4A s/seg.										Siemens	3NW7023	1	=QG		
	3FU4	3	BASE SEZ.X FUS.CILINDR.10x38 32A 3P 3UM FUSIBILI CILIND.-gG ACR 10,3x38-1A s/segn.										Siemens	3NW7033	1	=QG		
	3FU5	3	BASE SEZ.X FUS.CILINDR.10x38 32A 2P 2UM FUSE CILIND.-gG ACR 10,3x38-10A s/seg.										Siemens	3NW7023	1	=QG		
	3FU6	3	BASE SEZ.X FUS.CILINDR.10x38 32A 1P 1UM FUSE CILIND.-gG ACR 10,3x38-6A s/segn.										Siemens	3NW7013	1	=QG		
C	3GD1	3	Power supply AC/DC 60W - 24 Vdc										Rockwell Automation	1606-XL60D	1	=QG		
	3GD2	3	Power supply AC/DC 240W - 48 Vdc										Rockwell Automation	1606-XLE240F	1	=QG		
	3HL1	3	Hydro T8 920 FL1X18										Disano	16451000	1	=BM		
	3HL2	3	Voltage/Vision - Voltage Alert 3Ph - 30 mm										Grece Engineered Products Inc.	R-3W	1	=QG		
	3QS1	3	Switch 32 A 0-1, 3 pole mounted fund										Rockwell Automation	194E-A32-1753	1	=QG		
			4. NP pole for 32 A to A-194E										Rockwell Automation	194E-A32-NP	1			
			Extension shaft for 235mm metal 110 ... 194E-A / A-194L										Rockwell Automation	194L-G3393	1			
			Finitura N, 64x64 mm 0-1 per 194E / 194L										Rockwell Automation	194L-HE6N-175	1			
			Cover terminals for 3 poles 25/32 A for 194E										Rockwell Automation	194E-25-C3	1			
	3WB1	3	NSch Cu naked, 15 x 2 mm (80 A) TST (M 5)										Weidmuller	N028020	1	=QG		
3XS1	3	2 socket 2P + E 16A 50022 Universal Guide										Weidmuller	N128660	2				
4M2	4											Vimar	09967	1	=QG			
4M3	4													1	=BM			
4M4	4													1	=BM			
E	4QM2	4	Auto Switch. protezione engine for 4.0 ... 6.3 A Contact Block aus., mont. front interruption. Auto. 140M-C/D/F, 1 NO + 1 NC										Rockwell Automation	140M-C2E-B63	1	=QG		
	4QM3	4	Contact Block aus., mont. front interruption. Auto. 140M-C/D/F, 1 NO + 1 NC										Rockwell Automation	140M-C-AFA11	1	=QG		
			Interruttore autom. per protezione motore 0.16...0.25 A										Rockwell Automation	140M-C2E-A25	1			
	4QM4	4	Contact Block aus., mont. front interruption. Auto. 140M-C/D/F, 1 NO + 1 NC										Rockwell Automation	140M-C-AFA11	1	=QG		
			Interruttore autom. per protezione motore 0.16...0.25 A										Rockwell Automation	140M-C2E-A25	1			
	4QS2	4	P1-25/I2/SVB-SW/HI11 SEZ.3X25A 1NA+1NC CUST										Moeller	207295	1	=BM		
	5M1	5													1	=BM		
	5M2	5													1	=BM		
F	5QM1	5	Auto Switch. protezione engine for 1.0 ... 1.6 A Contact Block aus., mont. front interruption. Auto. 140M-C/D/F, 1 NO + 1 NC										Rockwell Automation	140M-C2E-B16	1	=QG		
	5QM2	5	Auto Switch. protezione engine for 1.0 ... 1.6 A										Rockwell Automation	140M-C-AFA11	1	=QG		
			Contact Block aus., mont. front interruption. Auto. 140M-C/D/F, 1 NO + 1 NC										Rockwell Automation	140M-C2E-B16	1	=QG		
	5QS1	5	P1-25/I2/SVB-SW/HI11 SEZ.3X25A 1NA+1NC CUST										Moeller	207295	1	=BM		
	5QS2	5	P1-25/I2/SVB-SW/HI11 SEZ.3X25A 1NA+1NC CUST										Moeller	207295	1	=BM		
	6FU1	6	BASE SEZ.X FUS.CILINDR.10x38 32A 3P 3UM FUSE CILIND.-gG ACR 10,3x38-10A s/seg.										Siemens	3NW7033	1	=QG		
6M1	6	Motore asincrono trifase										Legrand	013310	3				

G	DISEGNATORE DESIGNER		FD	IMPIANTO PLANT		SCHEMA ELETTRICO GESTIONE IMPIANTO ROTARY CAPS WIRING DIAGRAM PLANT GESTION ROTARY CAPS					CAD	SPAC	
	NOME FILE FILE NAME		EKI_01388	DATA REVISIONE REVISION DATE		REV. n° REV. nr°	COMMESSA ORDER	DATA DATE	DESCRIZIONE PAGINA PAGE DESCRIPTION		PAG.	DI OF	
	SCHEMA N° DIAGRAM NR.		EKI_01388	02/07/13		1	37016	11/01/2012	DISTINTA MATERIALI MATERIAL LIST		32	38	

	1	2	3	4	5	6	7	8	9		
A	THIS DRAWING SHALL NOT BE REPRODUCED OR IN ANY WAY UTILIZED WITHOUT WRITTEN CONSENT. ANY INFRINGEMENT WILL BE LEGALLY PURSUED.	Nome/Item	Fg/Sh	Descrizione/Description			Costruttore/Marke	Tipo/Type	Q.ta/Q.ty	Quadro/Board	
		6QS1	6	P1-25/I2/SVB-SW/HI11 SEZ.3X25A 1NA+1NC CUST			Moeller	207295	1	=BM	
		6U1	6	Inverter PowerFlex 40P DPI to EtherNet/IP Communications Modul Frame B Drive			Allen Bradley Allen Bradley Allen Bradley	22D-D2P3N104 22-COMM-E 22D-CCB	1 1 1	=QG	
		6Z1	6	EMC Filters			Allen Bradley	22-RF012-BS	1	=QG	
		7FU1	7	BASE SEZ.X FUS.CILINDR.10x38 32A 3P 3UM FUSE CILIND.-gG ACR 10,3x38-10A s/seg.			Siemens Legrand	3NW7033 013310	1 3	=QG	
		7M1	7						1	=BM	
		7QS1	7	P1-25/I2/SVB-SW/HI11 SEZ.3X25A 1NA+1NC CUST			Moeller	207295	1	=BM	
		7U1	7	Inverter PowerFlex 40P DPI to EtherNet/IP Communications Modul Frame B Drive			Allen Bradley Allen Bradley Allen Bradley	22D-D2P3N104 22-COMM-E 22D-CCB	1 1 1	=QG	
		7Z1	7	EMC Filters			Allen Bradley	22-RF012-BS	1	=QG	
		8FU1	8	BASE SEZ.X FUS.CILINDR.10x38 32A 3P 3UM FUSE CILIND.-gG ACR 10,3x38-10A s/seg.			Siemens Legrand	3NW7033 013310	1 3	=QG	
		8M1	8						1	=BM	
		8QS1	8	P1-25/I2/SVB-SW/HI11 SEZ.3X25A 1NA+1NC CUST			Moeller	207295	1	=BM	
B		8U1	8	Inverter PowerFlex 40P DPI to EtherNet/IP Communications Modul Frame B Drive			Allen Bradley Allen Bradley Allen Bradley	22D-D4P0N104 22-COMM-E 22D-CCB	1 1 1	=QG	
		8Z1	8	EMC Filters			Allen Bradley	22-RF012-BS	1	=QG	
		9A1	9	Emergency Stop module gate PNOZ X2.124 V AC/DC			Pilz	774 306	1	=QG	
		9EV1	9	Fan 120 x 120 x 20 Filter 130 x 130			Rittal Rittal	3322.027 3322.207	1 1	=QG	
		9FU1	9	BASE SEZ.X FUS.CILINDR.10x38 32A 1P 1UM FUSE CILIND.-gG ACR 10,3x38-6A s/seg.			Siemens Legrand	3NW7013 013306	1 1	=QG	
		9KA1	9	Mini relè per circuito stampato Zoccolo con morsetti a bussola Modulo indicatore LED+Diodo (polarità standard)			Finder Finder Finder	405290240000 9505SPA 9902902499	1 1 1	=QG	
		9SA1	9	Selector Switch Roins 2 Position Metal Latch Contact Block 1NO			Rockwell Automation Rockwell Automation Rockwell Automation	800FM-SM22 800F-ALM 800F-X10	1 1 1	=P1	
		9SB1	9	Emergency Stop Push Button Twist to Release - 40 mm Mushroom Metal Latch Contact Block 1NC Contact Block 1NO			Rockwell Automation Rockwell Automation Rockwell Automation Rockwell Automation	800FM-MT44 800F-ALM 800F-X01 800F-X10	1 1 4 1	=P1	
		9SB2	9	Emergency Stop Push Button Twist to Release - 40 mm Mushroom Metal Latch Contact Block 1NC Contact Block 1NO			Rockwell Automation Rockwell Automation Rockwell Automation Rockwell Automation	800FM-MT44 800F-ALM 800F-X01 800F-X10	1 1 4 1	=QG	
		9SH1	9	Push Button Illuminated Momentary Flush - Blue Metal Latch Integrated Module 24 Vdc - Blue Contact Block 1NO			Rockwell Automation Rockwell Automation Rockwell Automation Rockwell Automation	800FM-LF6 800F-ALM 800F-N3B 800F-X10	1 1 1 2	=P1	
		9SH2	9	Push Button Illuminated Momentary Flush - Blue			Rockwell Automation	800FM-LF6	1	=QG	
		C		DISEGNATORE DESIGNER		FD	IMPIANTO PLANT		SCHEMA ELETTRICO GESTIONE IMPIANTO ROTARY CAPS WIRING DIAGRAM PLANT GESTION ROTARY CAPS		
NOME FILE FILE NAME				EKI_01388	DATA REVISIONE REVISION DATE	REV. n° REV. nr°	COMMESSA ORDER	DATA DATE	DESCRIZIONE PAGINA PAGE DESCRIPTION	PAG.	DI OF
SCHEMA N° DIAGRAM NR.				EKI_01388	02/07/13	1	37016	11/01/2012	DISTINTA MATERIALI MATERIAL LIST	33	38
D		DISEGNATORE DESIGNER		FD	IMPIANTO PLANT		SCHEMA ELETTRICO GESTIONE IMPIANTO ROTARY CAPS WIRING DIAGRAM PLANT GESTION ROTARY CAPS			CAD	SPAC
		NOME FILE FILE NAME		EKI_01388	DATA REVISIONE REVISION DATE	REV. n° REV. nr°	COMMESSA ORDER	DATA DATE	DESCRIZIONE PAGINA PAGE DESCRIPTION	PAG.	DI OF
		SCHEMA N° DIAGRAM NR.		EKI_01388	02/07/13	1	37016	11/01/2012	DISTINTA MATERIALI MATERIAL LIST	33	38
E		DISEGNATORE DESIGNER		FD	IMPIANTO PLANT		SCHEMA ELETTRICO GESTIONE IMPIANTO ROTARY CAPS WIRING DIAGRAM PLANT GESTION ROTARY CAPS			CAD	SPAC
		NOME FILE FILE NAME		EKI_01388	DATA REVISIONE REVISION DATE	REV. n° REV. nr°	COMMESSA ORDER	DATA DATE	DESCRIZIONE PAGINA PAGE DESCRIPTION	PAG.	DI OF
		SCHEMA N° DIAGRAM NR.		EKI_01388	02/07/13	1	37016	11/01/2012	DISTINTA MATERIALI MATERIAL LIST	33	38
F		DISEGNATORE DESIGNER		FD	IMPIANTO PLANT		SCHEMA ELETTRICO GESTIONE IMPIANTO ROTARY CAPS WIRING DIAGRAM PLANT GESTION ROTARY CAPS			CAD	SPAC
		NOME FILE FILE NAME		EKI_01388	DATA REVISIONE REVISION DATE	REV. n° REV. nr°	COMMESSA ORDER	DATA DATE	DESCRIZIONE PAGINA PAGE DESCRIPTION	PAG.	DI OF
		SCHEMA N° DIAGRAM NR.		EKI_01388	02/07/13	1	37016	11/01/2012	DISTINTA MATERIALI MATERIAL LIST	33	38
G		DISEGNATORE DESIGNER		FD	IMPIANTO PLANT		SCHEMA ELETTRICO GESTIONE IMPIANTO ROTARY CAPS WIRING DIAGRAM PLANT GESTION ROTARY CAPS			CAD	SPAC
		NOME FILE FILE NAME		EKI_01388	DATA REVISIONE REVISION DATE	REV. n° REV. nr°	COMMESSA ORDER	DATA DATE	DESCRIZIONE PAGINA PAGE DESCRIPTION	PAG.	DI OF
		SCHEMA N° DIAGRAM NR.		EKI_01388	02/07/13	1	37016	11/01/2012	DISTINTA MATERIALI MATERIAL LIST	33	38



	1	2	3	4	5	6	7	8	9			
A	O	Nome/Item	Fg/Sh	Descrizione/Description		Costruttore/Marke		Tipo/Type	Q.ta/Q.ty	Quadro/Board		
		9SH2		Metal Latch Integrated Module 24 Vdc - Blue Contact Block 1N0		Rockwell Automation Rockwell Automation Rockwell Automation		800F-ALM 800F-N3B 800F-X10	1 1 2			
		10A1	10	Emergency Stop module gate PNOZ X2.1 24 V AC/DC		Pilz		774 306	1	=QG		
B		10KM1	10	Contactor 23 A 1 auxiliary contact, 24 VDC (Electronic Coil) Front mounting auxiliary contact block 1 NO + 1 NC 100-C09 ... C23 x 10 (23-24 / 31-32)		Rockwell Automation Rockwell Automation		100-C23EJ10 100-FC11	1 1	=QG		
		10KM2	10	Contactor 23 A 1 auxiliary contact, 24 VDC (Electronic Coil) Front mounting auxiliary contact block 1 NO + 1 NC 100-C09 ... C23 x 10 (23-24 / 31-32)		Rockwell Automation Rockwell Automation		100-C23EJ10 100-FC22	1 1	=QG		
		10S1	10						1	=BM		
		10S2	10						1	=BM		
		10S3	10						1	=BM		
		10S4	10						1	=BM		
		10S5	10						1	=BM		
		10S8	10						1	=BM		
		10S9	10						1	=BM		
		C		11A1	11	SISTEMA DI VISIONE		COGNEX		IS5400	1	=BM
11A2	11			SISTEMA DI VISIONE		COGNEX		IS5400	1	=BM		
11A3	11			ALIMENTATORE LAMPADE STROBOSCOPICHE		GARDASOFT VISION		PP500	1	=QG		
11HL1	11			LED					1	=BM		
11HL2	11								1	=BM		
12CPU1	12			CompactLogix controller type 1769-L32E		Allen-Bradley		1769-L32E	1	=QG		
D		12ECR	12	Cover right end		Allen-Bradley		1769-ECR	1	=QG		
		12ESP1	12	Input module: 32 Input 24V dc (current sinking / sourcing)		Allen-Bradley		1769-IQ32	1	=QG		
		12ESP2	12	Digital Output Module: 16 output 24V dc (current sourcing)		Allen-Bradley		1769-OB16	1	=QG		
		12ESP3	12	Input module: 16 Input 24V dc (current sinking / sourcing)		Allen-Bradley		1769-IQ16	1	=QG		
		12ESP4	12	Digital Output Module: 16 output 24V dc (current sourcing)		Allen-Bradley		1769-OB16	1	=QG		
		12GD1	12	Power supply - 24V DC power supply (4A at 5V dc 2A to 24V dc)		Allen-Bradley		1769-PB4	1	=QG		
		12OP1	12	PanelView Plus 400 Grayscale Terminals 3.8-inch, keyboard, Ethernet, RS-232 and Modular Communication Interface		Allen-Bradley		2711P-K4M20D	1	=P1		
		12XS1	12	Stratix 2000 Ethernet Unmanaged Switches - 8 Port Copper		Rockwell Automation		1783US08T	1	=QG		
		E		15SA1.5	15	Key Selector Switch Roins 3 Position Metal Latch Contact Block 1N0		Rockwell Automation Rockwell Automation Rockwell Automation		800FM-KM34 800F-ALM 800F-X10	1 1 2	=P1
				15SA1.7	15	Selector Switch Not-Illuminated 2 Position Maintained Metal Latch Contact Block 1N0		Rockwell Automation Rockwell Automation Rockwell Automation		800FM-SM22 800F-ALM 800F-X10	1 1 1	=P1
15SB1.4	15			Push Button Not-Illuminated Momentary Flush - Black Metal Latch Contact Block 1NC		Rockwell Automation Rockwell Automation Rockwell Automation		800FM-F2 800F-ALM 800F-X01	1 1 1	=P1		
15SH1.3	15			Push Button Illuminated Momentary Flush - Green Metal Latch Integrated Module 24 Vdc - Green Contact Block 1N0		Rockwell Automation Rockwell Automation Rockwell Automation Rockwell Automation		800FM-LF3 800F-ALM 800F-N3G 800F-X10	1 1 1 1	=P1		
16SB1.9	16			Push Button Not-Illuminated Momentary Flush - Green Metal Latch Contact Block 1N0		Rockwell Automation Rockwell Automation Rockwell Automation		800FM-F3 800F-ALM 800F-X10	1 1 1	=P1		
G				DISEGNATORE DESIGNER	FD		IMPIANTO PLANT	SCHEMA ELETTRICO GESTIONE IMPIANTO ROTARY CAPS WIRING DIAGRAM PLANT GESTION ROTARY CAPS			CAD	SPAC
		NOME FILE FILE NAME	EKI_01388		DATA REVISIONE REVISION DATE	REV. n° REV. nr°	COMMESSA ORDER	DATA DATE	DESCRIZIONE PAGINA PAGE DESCRIPTION	PAG.	DI OF	
		SCHEMA N° DIAGRAM NR.	EKI_01388		02/07/13	1	37016	11/01/2012	DISTINTA MATERIALI MATERIAL LIST	34	38	



1		2		3		4		5		6		7		8		9	
Nome/Item		Fg/Sh		Descrizione/Description				Costruttore/Marke		Tipo/Type		Q.ta/Q.ty		Quadro/Board			
A	16SB2.0	16	Push Button Not-Illuminated Momentary Flush - Green Metal Latch Contact Block 1N0				Rockwell Automation		800FM-F3		1		=QG				
	17BF1.17R	10A									1		=BM				
	17BF1.17T	10A	Interruttore fotoelettrico. Emittitore alimentato in D.C.								1		=BM				
	17BF1.18	17									1		=BM				
	17BF1.19R	17									1		=BM				
	17BF1.19T	17	Interruttore fotoelettrico. Emittitore alimentato in D.C.								1		=BM				
	17BF1.20R	17									1		=BM				
	17BF1.20T	17	Interruttore fotoelettrico. Emittitore alimentato in D.C.								1		=BM				
	17BF1.21R	10A									1		=BM				
	17BF1.21T	10A	Interruttore fotoelettrico. Emittitore alimentato in D.C.								1		=BM				
B	17SA1.16	10A	Key Selector Switch Roins 2 Position Metal Latch Contact Block 1N0				Rockwell Automation		800FM-KM23		1		=BM				
	17SP1.22	17									1		=BM				
	17SQ1.23	17									1		=BM				
	18S1.26	10A									1		=BM				
	20KM2.2	20	Contactor auxiliary contact 19 A, 24 VDC (Electronic Coil)				Rockwell Automation		100-C09EJ10		1		=QG				
	20KM2.3	20	Contactor auxiliary contact 19 A, 24 VDC (Electronic Coil)				Rockwell Automation		100-C09EJ10		1		=QG				
	20KM2.5	20	Contactor auxiliary contact 19 A, 24 VDC (Electronic Coil)				Rockwell Automation		100-C09EJ10		1		=QG				
	20KM2.6	20	Contactor auxiliary contact 19 A, 24 VDC (Electronic Coil)				Rockwell Automation		100-C09EJ10		1		=QG				
	21HA2.8	21									1		=BM				
	21HL2.10	21									1		=BM				
C	21HL2.11	21									1		=BM				
	21HL2.12	21									1		=BM				
	21HL2.9	21									1		=BM				
	21YV2.13	21									1		=BM				
	21YV2.15	21									1		=BM				
	22ABF3.10	22A	Interruttore fotoelettrico. Emittitore-Ricevitore 3 fili NO alimentato in D.C.								1		=BM				
	22BKM4.3	22B	Contactor auxiliary contact 19 A, 24 VDC (Electronic Coil)				Rockwell Automation		100-C09EJ10		1		=QG				
	22BKM4.4	22B	Contactor auxiliary contact 19 A, 24 VDC (Electronic Coil)				Rockwell Automation		100-C09EJ10		1		=QG				
	22BYV4.0	11A	Elettrovalvola aperta (in chiusura)								1		=BM				
	22BYV4.1	11A									1		=BM				
D	K1	11A	DEK-OE- 24DC/48DC/100 Optoaccoppiatore				Phoenix Contact		294.0207		1		=QG				
	K2	11A	DEK-OE- 24DC/48DC/100 Optoaccoppiatore				Phoenix Contact		294.0207		1		=QG				
	K3	11A	DEK-OE- 24DC/48DC/100 Optoaccoppiatore				Phoenix Contact		294.0207		1		=QG				
	K4	11A	DEK-OE- 24DC/48DC/100 Optoaccoppiatore				Phoenix Contact		294.0207		1		=QG				
	KY1	11A	DEK-OE- 24DC/48DC/100 Optoaccoppiatore				Phoenix Contact		294.0207		1		=QG				
	KY2	11A	DEK-OE- 24DC/48DC/100 Optoaccoppiatore				Phoenix Contact		294.0207		1		=QG				
	X10		Morsetto componibile conduttore di protezione WPE 2.5 Morsetto componibile di passaggio WDU 2.5 Terminale di fissaggio per TS 35 WEW 35/2 Piastra terminale / parete di separazione WAP 2.5-10				Weidmuller		1010000000		2		=BM				
							Weidmuller		1020000000		24		=BM				
							Weidmuller		1061200000		2		=BM				
							Weidmuller		1050000000		5		=BM				
E	XC1		Connettore 10 poli + terra, 16A - 400V, connessioni a vite, frutto Femmina				Harting		0933 010 2701		1		=BM				
	DISEGNATORE DESIGNER		FD		IMPIANTO PLANT		SCHEMA ELETTRICO GESTIONE IMPIANTO ROTARY CAPS WIRING DIAGRAM PLANT GESTION ROTARY CAPS					CAD		SPAC			
	NOME FILE FILE NAME		EKI_01388		DATA REVISIONE REVISION DATE		REV. n° REV. nr°		COMMESSA ORDER		DATA DATE		DESCRIZIONE PAGINA PAGE DESCRIPTION		PAG. DI OF		
	SCHEMA N° DIAGRAM NR.		EKI_01388		02/07/13		1		37016		11/01/2012		DISTINTA MATERIALI MATERIAL LIST		35 38		



THIS DRAWING SHALL NOT BE REPRODUCED OR IN ANY WAY UTILIZED WITHOUT WRITTEN CONSENT. ANY INFRINGEMENT WILL BE LEGALLY PURSUED.

Nome/Item	Fg/Sh	Descrizione/Description	Costruttore/Marke	Tipo/Type	Q.ta/Q.ty	Quadro/Board
XC1		Connettore 10 poli + terra, 16A - 400V, connessioni a vite, frutto Maschio	Harting	0933 010 2601	1	=BM
		Custodia da parete chiusura doppia con leve, uscita M25	Harting	1930 010 1231	1	=BM
		Custodia mobile chiusura doppia con piolini, uscita orizzontale M25	Harting	1930 010 1521	1	=BM
XC10		Connettore 16 poli + terra, 16A - 400V, connessioni a vite, frutto Femmina	Harting	0933 016 2701	1	=BM
		Connettore 16 poli + terra, 16A - 400V, connessioni a vite, frutto Maschio	Harting	0933 016 2601	1	=BM
		Custodia da parete chiusura doppia con leve, uscita M25	Harting	1930 016 1231	1	=BM
		Custodia mobile chiusura doppia con piolini, uscita orizzontale M25	Harting	1930 016 1521	1	=BM
X20		Morsetto componibile di passaggio WDU 2.5	Weidmuller	1020000000	42	=P1
		Terminale di fissaggio per TS 35 WEW 35/2	Weidmuller	1061200000	2	=P1
		Morsetto componibile conduttore di protezione WPE 2.5	Weidmuller	1010000000	1	=P1
		Piastra terminale / parete di separazione WAP 2.5-10	Weidmuller	1050000000	1	=P1
XC12		Connettore maschio per montaggio su telaio, attacco a baionetta, 3 poli	Neutrik	405607	1	=P1
		Connettore femmina per montaggio su cavo, attacco a baionetta, 3 poli	Neutrik	405613	1	=P1
3QS1		Morsetto componibile conduttore di protezione WPE 4	Weidmuller	1010100000	1	=QG
X1		Morsetto componibile conduttore di protezione WPE 2.5	Weidmuller	1010000000	5	=QG
		Morsetto componibile di passaggio WDU 2.5	Weidmuller	1020000000	17	=QG
		Terminale di fissaggio per TS 35 WEW 35/2	Weidmuller	1061200000	2	=QG
		Piastra terminale / parete di separazione WAP 2.5-10	Weidmuller	1050000000	5	=QG
		Piastra terminale / parete di separazione WAP	Weidmuller	1059100000	6	=QG
		Morsetto doppio WDK 2.5	Weidmuller	1021500000	83	=QG
		Morsetto doppio WDK 2.5PE	Weidmuller	1036300000	1	=QG
X100		Terminale di fissaggio per TS 35 WEW 35/2	Weidmuller	1061200000	2	=QG
		Piastra terminale / parete di separazione WAP	Weidmuller	1059100000	1	=QG
		Morsetto doppio WDK 2.5	Weidmuller	1021500000	9	=QG
EMPTYING PUSHBUTTON BOX		Button 1 Hole - 92 x 92 x 70	Elfin	040C0909-7EP1	1	=BM
POWER BOX		Box - 190 x 140 x 70	Gewiss	GW44207	1	=BM
		Plate	Gewiss	GW44615	1	=BM
COMMAND BOX		Box - 240 x 190 x 90	Gewiss	GW44208	1	=BM
		Plate	Gewiss	GW44616	1	=BM

DISEGNATORE DESIGNER	FD	IMPIANTO PLANT	SCHEMA ELETTRICO GESTIONE IMPIANTO ROTARY CAPS WIRING DIAGRAM PLANT GESTION ROTARY CAPS				CAD	SPAC	 bonino ®
NOME FILE FILE NAME	EKI_01388	DATA REVISIONE REVISION DATE	REV. n° REV. nr°	COMMESSA ORDER	DATA DATE	DESCRIZIONE PAGINA PAGE DESCRIPTION	PAG.	DI OF	
SCHEMA N° DIAGRAM NR.	EKI_01388	02/07/13	1	37016	11/01/2012	DISTINTA MATERIALI MATERIAL LIST	36	38	

THIS DRAWING SHALL NOT BE REPRODUCED OR IN ANY WAY UTILIZED WITHOUT WRITTEN CONSENT. ANY INFRINGEMENT WILL BE LEGALLY PURSUED.

Nome/Item	Fg/Sh	Descrizione/Description	Costruttore/Marke	Tipo/Type	Q.ta/Q.ty	Quadro/Board
9SA1	9	Selector Switch Roins 2 Position	Rockwell Automation	800FM-SM22	1	=P1
		Metal Latch	Rockwell Automation	800F-ALM	1	
		Contact Block 1NO	Rockwell Automation	800F-X10	1	
9SB1	9	Emergency Stop Push Button Twist to Release - 40 mm Mushroom	Rockwell Automation	800FM-MT44	1	=P1
		Metal Latch	Rockwell Automation	800F-ALM	1	
		Contact Block 1NC	Rockwell Automation	800F-X01	4	
		Contact Block 1NO	Rockwell Automation	800F-X10	1	
9SH1	9	Push Button Illuminated Momentary Flush - Blue	Rockwell Automation	800FM-LF6	1	=P1
		Metal Latch	Rockwell Automation	800F-ALM	1	
		Integrated Module 24 Vdc - Blue	Rockwell Automation	800F-N3B	1	
		Contact Block 1NO	Rockwell Automation	800F-X10	3	
120P1	12	PanelView Plus 400 Grayscale Terminals 3.8-inch, keyboard, Ethernet, RS-232 and Modular Communication Interface	Allen-Bradley	2711P-K4M20D	1	=P1
15SA1.5	15	Key Selector Switch Roins 3 Position	Rockwell Automation	800FM-KM34	1	=P1
		Metal Latch	Rockwell Automation	800F-ALM	1	
		Contact Block 1NO	Rockwell Automation	800F-X10	2	
15SA1.7	15	Selector Switch Not.Illuminated 2 Position Maintained	Rockwell Automation	800FM-SM22	1	=P1
		Metal Latch	Rockwell Automation	800F-ALM	1	
		Contact Block 1NO	Rockwell Automation	800F-X10	1	
15SB1.4	15	Push Button Not-Illuminated Momentary Flush - Black	Rockwell Automation	800FM-F2	1	=P1
		Metal Latch	Rockwell Automation	800F-ALM	1	
		Contact Block 1NC	Rockwell Automation	800F-X01	1	
15SH1.3	15	Push Button Illuminated Momentary Flush - Green	Rockwell Automation	800FM-LF3	1	=P1
		Metal Latch	Rockwell Automation	800F-ALM	1	
		Integrated Module 24 Vdc - Green	Rockwell Automation	800F-N3G	1	
		Contact Block 1NO	Rockwell Automation	800F-X10	1	
16SB1.9	16	Push Button Not-Illuminated Momentary Flush - Green	Rockwell Automation	800FM-F3	1	=P1
		Metal Latch	Rockwell Automation	800F-ALM	1	
		Contact Block 1NO	Rockwell Automation	800F-X10	1	
X20		Morsetto componibile di passaggio WDU 2.5	Weidmuller	1020000000	40	=P1
		Terminale di fissaggio per TS 35 WEW 35/2	Weidmuller	1061200000	2	=P1
		Morsetto componibile conduttore di protezione WPE 2.5	Weidmuller	1010000000	1	=P1
		Piastra terminale / parete di separazione WAP 2.5-10	Weidmuller	1050000000	1	=P1
XC12		Socket for mounting on a chassis, bayonet, 3-pin	Neutrik	405613	1	=P1
		Male Cable Mount Connector, Bayonet, 3-pin	Neutrik	405607	1	=P1
		Pushbutton portable 3-hole	Rockwell Automation	800C-P03Z	1	=P1
		Spiral Cable	Reiter	70002629	1	=P1
PUSHBUTTON BOX		Box - 300 x 400 x 120	Rittal	KL1508.510	1	=P1

DISEGNATORE DESIGNER	FD	IMPIANTO PLANT	SCHEMA ELETTRICO GESTIONE IMPIANTO ROTARY CAPS WIRING DIAGRAM PLANT GESTION ROTARY CAPS				CAD	SPAC	 bonino ®
NOME FILE FILE NAME	EKI_01388	DATA REVISIONE REVISION DATE	REV. n° REV. nr°	COMMESSA ORDER	DATA DATE	DESCRIZIONE PAGINA PAGE DESCRIPTION	PAG.	DI OF	
SCHEMA N° DIAGRAM NR.	EKI_01388	02/07/13	1	37016	11/01/2012	DISTINTA MATERIALI MATERIAL LIST	37	38	

THIS DRAWING SHALL NOT BE REPRODUCED OR IN ANY WAY UTILIZED WITHOUT WRITTEN CONSENT. ANY INFRINGEMENT WILL BE LEGALLY PURSUED.

A

B

C

D

E

F

G

A

B

C

D

E

F

G

1

2

3

4

5

6

7

8

9

DISEGNATORE
DESIGNER

FD

IMPIANTO
PLANT

SCHEMA ELETTRICO GESTIONE IMPIANTO ROTARY CAPS
WIRING DIAGRAM PLANT GESTION ROTARY CAPS

CAD

SPAC

NOME FILE
FILE NAME

EKI_01388

DATA REVISIONE
REVISION DATE

REV. n°
REV. nr°

COMMESSA
ORDER

DATA
DATE

DESCRIZIONE PAGINA
PAGE DESCRIPTION

PAG.

DI
OF

SCHEMA N°
DIAGRAM NR.

EKI_01388

02/07/13

1

37016

11/01/2012

38

38



1

2

3

4

5

6

7

8

9